

MBE01

Espresso machine



EN Read the manual before installing, using and servicing the machine.
This manual is intended for dealers and mechanics who are qualified and instructed to perform service to the machine.

Preface

Please read this manual carefully before executing service labour to the dispenser!

This service manual is intended exclusively for technical support to be executed by a qualified or licensed mechanic. The demands for a qualified mechanic are:

The mechanic is well known in the workings of the dispenser/machine, by training at Veromatic International BV or an equal training elsewhere (dealer for instance).

The mechanic is well known of all laws and regulations in the area of safety, electrical connections/symbols, etc.

The mechanic uses the instructions and schemes valid for this machine type/model. These technical documents are supplied by the dealer.

For service labour is required:

This Service manual

The User manual supplied with all machines

The Spare parts manual

Tooling.

Attention! This manual is NOT intended for the end user or the operator of the dispenser. They refer to the user manual supplied with the machine.

Nothing in this publication may be copied, included in an automatic information base, and / or published in any form or way, be it electronic, mechanical, by photocopies, pictures or in any other way, without previous written permission from Veromatic International B.V.

Although this manual has been produced with the utmost care, no legal claims can be derived here from. Veromatic International B.V. maintains the right to change the product without prior notice.

Fabrikant:

VEROMATIC INTERNATIONAL BV

Donker Duyvisweg 56



3316 BM Dordrecht

The Netherlands

Nothing in this publication may be copied, included in an automatic information base, and / or published in any form or way, be it electronic, mechanical, by photocopies, pictures or in any other way, without previous written permission from Veromatic International B.V.

Although this manual has been produced with the utmost care, no legal claims can be derived here from. Veromatic International B.V. maintains the right to change the product without prior notice.

Contents

Preface	2	5.1 Taking a drink	20
1 Important	5	5.2 Hot water	22
1.1 Safety regulations	5	5.3 Jug/cup-to-go function	22
1.2 Users' qualifications	5	5.4 Energy save mode (VIPS).....	23
1.3 Use environment	5	5.5 Rinse menu and service menu.....	23
1.4 Original parts	5	6 Maintenance	24
1.5 Hygiene	5	6.1 The maintenance area	24
1.6 Ingredients	6	6.2 The service area	24
1.7 Ventilation openings.....	6	6.3 Freezing solid	24
1.8 Water filter	6	6.4 Machine overview.....	25
1.9 Water temperature.....	6	6.5 Rinse/maintenance menu.....	25
1.10 Dispense time.....	6	6.6 Daily maintenance.....	27
1.11 Electrical safety	6	6.7 Weekly maintenance.....	28
1.12 Liability and warranty.....	6	6.7.1 Cleaning brewer	28
1.13 Personal safety.....	7	6.7.2 Cleaning instant mixer.....	31
2 Transportation and unpacking	8	6.7.3 Filling bean hopper	34
2.1 Transportation	8	6.7.4 Filling instant canisters.....	34
3 Installation	9	6.8 Monthly maintenance	36
3.1 Operation schematic	9	6.9 Annual maintenance	36
3.2 General installation guidelines.....	9	8 Service menu	37
3.3 Installation location	10	8.1 Extended machine settings	37
3.4 Water connection.....	11	8.2 Extended navigation	37
3.5 Electrical connection	11	8.3 BASIC -  MENU LEVEL	40
3.6 Interface operation (short)	12	8.4 Password protection for higher levels ...	41
3.7 First installation	13	8.4.1 ADVANCED -  & SUPERVISOR -	
3.7.1 Standard configuration	13	 MENU LEVEL	42
3.7.2 Alternative configuration	13	9 Machine electronics	50
3.7.3 Taste card installation.....	14	9.1 Overview electronics	50
3.7.4 Using a customized key layout	15	9.1.1 PP-00581 main I/O board.....	51
3.8 Start Up	15	9.1.2 PP-00880 interface board.....	52
3.9 Customization of bean grind and product settings	16	9.1.3 PP-00851 Converter and protection circuitry for 230 VDC grinding motor.....	53
3.10 Instructions for the operator	16	9.2 Electrical wiring diagram.....	54
4 Adjustments	17	10 Service	55
4.1 Introduction	17	10.1 Safety and hygiene.....	55
4.2 Products	17	10.2 Water lock and water filter	55
4.3 Water temperature.....	17	10.3 Safety inspection	55
4.4 Grinder adjustment	18	10.4 Hygiene.....	55
4.5 Canister calibration.....	18	10.5 Maintenance schedule	56
5 Operation	19		

- 12 Malfunctions & repairs58**
 - 12.1 Display malfunction messages58
 - 12.2 Repairs 60
- 13 Decommissioning..... 61**
 - 13.1 Temporary decommissioning 61
 - 13.2 Disposal 61
- 14 Technical information 62**
 - 14.1 EU-declaration of conformity 63

1 Important

1.1 Safety regulations

This machine is exclusively intended for the preparation of soup based on hot drinks, such as espresso, coffee, cappuccino, hot chocolate based on fresh ground beans and freeze dried milk and chocolate powder. Using the hot water key, other hot drinks can be prepared, such as hot tea.

It is forbidden to use the machine for other purposes than described above. Do not place the machine in areas where high pressure or steam is used to clean.

Read the directions and especially these safety guidelines, before you install or use this machine. Keep this manual with the machine to be able to consult them at a later time.

The following symbols indicate WARNINGS or safety risks:



WARNING

Indicates a risk situation that may cause severe personal injury, danger to life and / or damage to the machine.



ATTENTION

Indicates a risk situation that may cause unsubstantial personal injury and / or damage to the machine.



BEWARE

Danger of electrical voltage.

1.2 Users' qualifications

This machine is not intended for use by persons with reduced physical, sensory or mental capacities, or lack of experience and knowledge, unless they have been supervised or have been instructed about the use of the device by a person responsible for their safety.

Children may not operate the device and have to be supervised to ensure that they cannot play with the device.

1.3 Use environment

The machine may only be used indoors, not outdoors. Place in a frost free area (between 10 and 32° C.) where it is not exposed to humidity or excessive dust and cannot be sprayed with liquids.

1.4 Original parts

When replacing parts, only use original (spare) parts, available from Veromatic International B.V. This also applies for the options mentioned. Parts must meet strict quality demands through which the machine will continue to function optimally. When parts are used that are not original then the warranty is null and void and Veromatic International B.V. is not responsible for any possible damage that may occur as a result thereof.

1.5 Hygiene

For a good hygiene and safety it is important to maintain the machine according to the regulations. Clean the product canisters and the removable parts that come into contact with food according to the

regulations in this manual and make sure they are thoroughly dry before replacing them in the machine.

1.6 Ingredients

Observe the storage and application regulations on the packaging of the ingredients. Make sure that the ingredients do not become moist. Remove the ingredients that have been in the canister too long or if you have doubts about their quality.

1.7 Ventilation openings

Prevent objects or liquids from entering the machine through the ventilation openings. Immediately pull out the plug if liquids enter the machine inadvertently. Never spray water with a hose or other implement in the direction of the machine.

1.8 Water filter

The water filter (optional) has to be replaced every 6 months, or after about 30,000 drinks. Your dealer can inform you about this. A water filter used too long is detrimental for the operation of the machine and can be dangerous for the health.

Do not use the water filter in areas where the water is not safe microbiologically or in areas where the quality of the water is unknown. Follow the installation regulations as described in paragraph 3.1 or follow the installation directions for the water filter.

1.9 Water temperature

In the machine there is also a water boiler with a water temperature of 80-95°C. The water remains hot for a long time, even when the machine has been turned off.

Keep your hands away from the spout / cup when taking a drink or when rinsing, to prevent burns caused by the hot water.

1.10 Dispense time

The drink will be dispensed almost immediately after making the selection.

1.11 Electrical safety



BEWARE:

No parts may be removed if it requires tools. This may only be done by a licensed technician. See also paragraph 3.1.

Do not use objects to poke into the different openings of the machine and do not spray water into or on the machine. The machine may also not be placed in areas where cleaning takes place with steam or high pressure devices.

1.12 Liability and warranty

With reference to the terms of delivery of Veromatic International BV, it is not liable and liable for warranty as a result of:

- normal wear and tear
- external damage
- faulty and injudicious use
- Installation, assembly, modification or repair not carried out according to the manufacturer's guidelines

- not or incorrectly performed maintenance
- defects in or unsuitability of goods or used materials or tools by instructions or third parties.

1.13 Personal safety

Mind the following points before performing maintenance, to ensure a safe working environment:

1. Make sure the machine complies to the connection requirements.
2. When working on the machine, make sure the machine is without power. Remove the mains cable from the wall socket. If the maintenance requires to have the machine on power, be very careful.
3. The water in the boiler remains hot for a long time, even after removing the power. Be careful to avoid burns of hot water.
4. Do not stick sharp objects through openings, unless specific maintenance actions require this, and no damage may be done to wirings or components.
5. Do not put drinks or containers on top of the machine.
6. Do not clean the internals of the machine with wet cloths when safety covers are removed.
7. Never aim a water hose to the machine.
8. Check if removed earthing connections are re-applied the correct way and perform their function as intended.

2 Transportation and unpacking

2.1 Transportation

The transportation of this machine may only occur in the original packaging. Instructions necessary to store and transport this machine are located on the packaging.

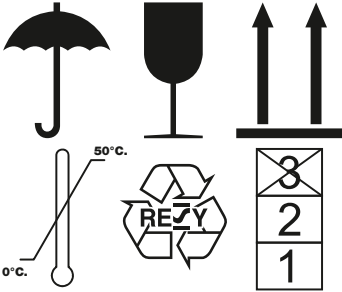

/2.1

Environmental temperature

During operation	+10° to +32°	Celsius
During transport and storage	+0° to +50°	Celsius

Dimensions packaging and transport weight

Height	680	mm
Width	410	mm
Depth	595	mm
Weight	34.5	kg

Check the packaging for damages. A damaged machine may be unsafe and may not be put into service. In such a case, contact your dealer. Save the packaging if you expect that the machine may have to be moved at a later date.

3 Installation

⚠ WARNING:

Only a qualified service technician may install the machine!

3.1 Operation schematic

- 1 Water connection
- 2 Reducing valve (optional)
- 3 Water filter (optional)
- 4 Intake valve
- 5 Air break
- 6 Flow meter
- 7 Pressure pump
- 8 Non-return valve
- 9 Bypass valve
- 10 Espresso boiler
- 11 Threeway valve
- 12 Outlet valve 1 hot water
- 13 Outlet valve 2 extra hot water
- 14 Outlet valve 3 mixer
- 15 Overflow to drip tray
- 16 Bean canister
- 17 Instant product canisters
- 18 Bean grinder
- 19 Espresso brewer
- 20 Safety switches brewer/grinder
- 21 Waste bin
- 22 Mixer unit
- 23 Cup sensor left outlet
- 24 Cup sensor right outlet

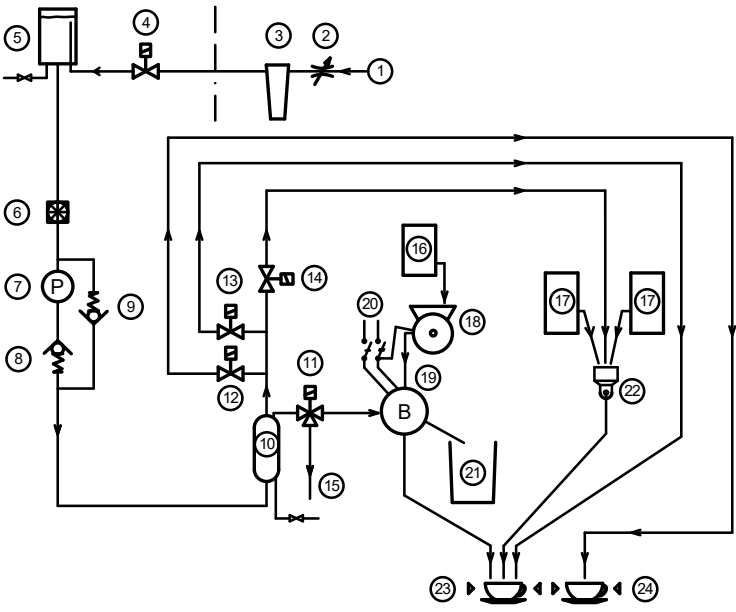

/ 3-1

The products are prepared according to several principles: espresso and instant.

The espresso/coffee products are prepared in the espresso brewer at approx. 8-9 bar. The water is pressurized by the water pump, heated by the espresso boiler and subsequently flowing to the espresso brewer. Before that, beans are ground to powder and dispensed in the brewer. The bean variety, grind size, ground weight and pressing of the powder will affect the water pressure and the in-cup quality.

Mix products are prepared according to the instant principle. The hot water required comes from the espresso water boiler. A certain amount of hot water and powder(s) are being dispensed and brought together in a mixer unit. In this unit both components are mixed by means of a quickly rotating mixer. This mixture is being poured, whether or not combined with another soluble product, from the spout into the cup or decanter.

3.2 General installation guidelines

The installation of the machine may only be done by a qualified service technician. This technician must adhere to the guidelines issued by the manufacturer of the machine in accordance with the national and

local legal guidelines. The technician instructs the operator about the operation, the maintenance and the proceedings during possible malfunctions.

Do not place the machine in areas that are cleaned with water jets or steam.

It is required that a sufficiently fused wall outlet with proven grounding is present within 1½ meters and an aerated washing machine faucet.

Besides the legal guidelines that a service technician has to meet, Veromatic International BV moreover makes the following demands of a service technician:

- 1 The technician must be very well acquainted with the machine, through training by Veromatic International B.V. or through similar training obtained elsewhere.
- 2 The technician must use the instructions, diagrams etc. that are applied to this type and model.
- 3 The technician is well informed about the applicable guidelines for hygiene.

3.3 Installation location

The machine is intended only for use indoors, not outdoors. Place the machine in a frost-free location where it is not exposed to moisture or excessive dust and cannot be sprayed with liquids. The machine may not be used at an elevation over 2000 m.

The machine is only suited for use in household, office and light-industrial environments. The machine is not suitable for professional kitchens where cleaning frequently occurs with water or in a dusty environment. When placed in another environment, Veromatic International cannot guarantee the correct operation or the safety of the machine.

Do not place the machine in areas that are cleaned with water jets or steam.

For correct operation the machine may not be installed at an angle, but at a **flat and stable** surface.

The ambient temperature has to be within +10° to +32° Celsius for a correct operation of the machine.

Make sure that the wall outlet and the water valve remain free and easily accessible after placement of the machine.

The main power switch is located on the back of the machine. Make sure that this also remains easily accessible.

Check to see that the electrical cable is not damaged. A damaged electrical cable must be replaced immediately!

Make sure there is enough open space around the machine. Minimum needed dimensions (in mm) see /3-2.

Place the machine as such that the highest surface of the machine is located at least 120 cm above the floor surface.

If the unit is placed directly underneath a cupboard, allow a space of at least 150 mm. For a proper operation of the machine it is necessary that cooling air can be supplied and discharged. For this purpose many ventilation openings have been made in the machine. These openings may never be covered.

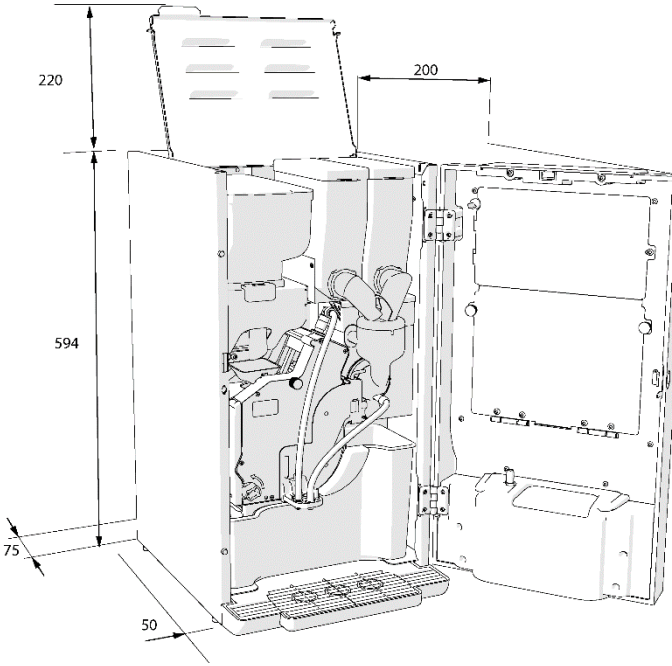

/3-2

3.4 Water connection

Connection data water

Water connection	3/4"	BSP
Water pressure	2.0 – 8.0	bar
	0.2 – 0.8	MPa

Water lock
Veromatic International BV instructs the use of a water lock (Veromatic order code HL-00190) and does not accept any responsibility with regard to water damage, in case the machine gets installed without this water lock.

Water filter
Install a water filter to ensure the best taste quality and to reduce scale and thus maintenance. Replace the water filter regularly. See the water filter specification for information. Your dealer can inform you about a water filter and installment.

The machine must be placed within a distance of 1½ meters from an aerated washing machine tap on a riser pipe, which relates to the current regulations of the water company and the above-mentioned operating pressure.

The dispenser must be equipped with a flexible hose set (not supplied) that complies with the current water and food regulations of the country. The hose must be equipped on the machine side with a gland with seal. Whether the machine is new or a replacement, always use a new hose set for the water supply. Do not reuse the old set for safety reasons.

Connection procedure

1. Attach the water hose to the tap.
2. Rinse the water supply thoroughly so possible dirt cannot enter the machine.
3. When using a water filter, follow the installation guideline of it's manual.
4. Attach the water hose to the inlet valve on the machine. Tighten the gland well.
5. Check to see if there are no kinks or damages on the hose.
6. Open the faucet.
7. Check for leakage.

3.5 Electrical connection

- The machine must be connected with the supplied power cord.
- It is required that a sufficiently fused socket outlet with proven grounding is present within 1½ meters.
- Use a separate group, for this machine only, with a 16A fuse.

Electrical specifications

Power supply	230	V~
Frequency	50	Hz
Electrical capacity	2000	W
Electrical safety class	Class I	
IP classification	IP20	
Pollution grade	2	
Overvoltage category	II	



ATTENTION:

Allow the machine to acclimate. For that purpose, leave it at least half an hour standing on the operation location, before plugging it in.

3.6 Interface operation (short)

The interface of the machine consist of a two line information display, LED lit capacitive touch buttons and information LED's. The interface operates in two states, normal vending operation and menu navigation.

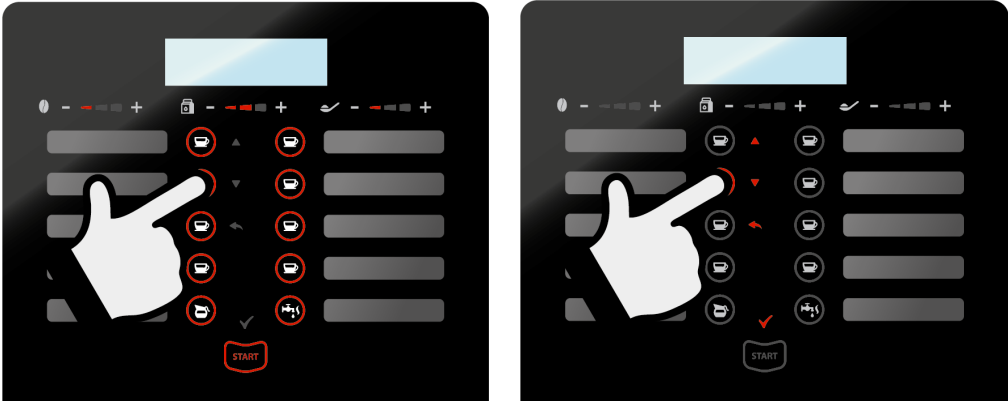

/3-3

When opening the door, the maintenance menu is activated by activating the door switch (/4-1). When doing this, the navigation symbols are lit (/4-2). Navigation is done by pressing the round touch keys next to these symbols.

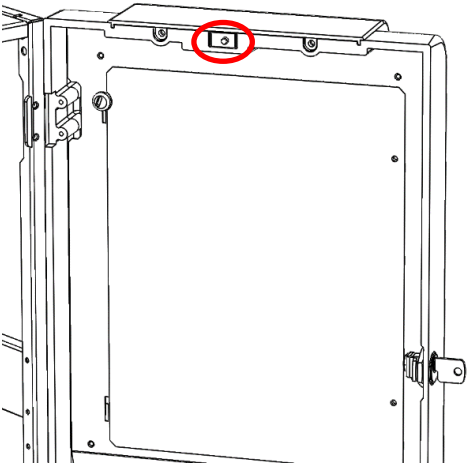

/4-1

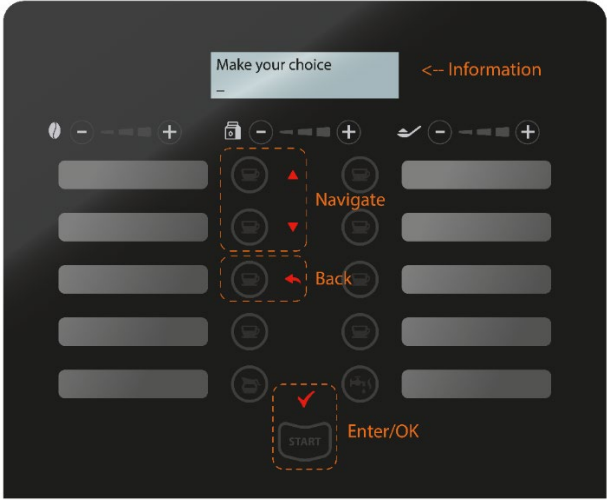

/4-2

UP / DOWN button

The navigate buttons (UP and DOWN arrow) are used for scrolling through the menu options.

ENTER button

For accessing options deeper into the menu.

BACK button

For returning to a higher level in the menu or exiting the maintenance menu (from the top level).

3.7 First installation

The machine is provided with two empty taste cards and a sheet of product stickers. Before commissioning the correct stickers have to be placed onto the taste cards and installed behind the glass. The correct sticker placement should correspond to the configuration of the machine. This can be modified if wished by the service technician.

3.7.1 Standard configuration

The following configuration is pre-programmed as standard.

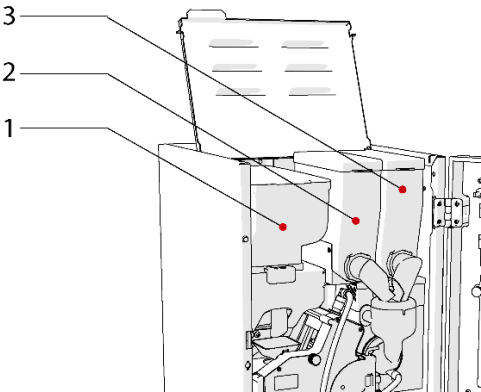

/3-3

Standard canister configuration (301)

Canister	Product
1	Coffee beans
2	Topping
3	Cacao

Standard taste card order

Left taste card	Right taste card
Espresso	Cappuccino
Coffee	Latte Macchiato
Cafe Americano	Cafè latte
Wiener Melange	Chocolate
Jug	Hot water

3.7.2 Alternative configuration

A second configuration is build-in off factory for use with a different canister layout.

Alternative canister configuration (302)

Canister	Product
1	Coffee beans
2	Topping
3	Sugar

Alternative taste card order

Left taste card	Right taste card
Espresso	Cappuccino
Coffee	Latte Macchiato
Cafe Americano	Café latte
Double espresso	
Jug	Hot water

Procedure for changing the configuration:

1. Open the door with key and go to the rinse menu.
2. Scroll down to 'password' then press start.
3. Enter the password as '2222' with the help of down scroll key, it will enable the factory menu.
4. Select 'load defaults', it will ask you 'Defaults will overwrite all settings!' and counters will be reset are you sure?". Select start to accept. Machine will restart.
5. After machine restarts, it will show the machine types. Select your machine type as Minibar Espresso.
6. It will ask you configuration type, select the required configuration as config 1 or config 2.

Before changing the machine configuration from software, make sure that your canister type and content is per the new configuration. Refer above tables for canister contains for the specific configuration.

Modification of the cacao canister to a sugar canister can be done by simply removing the agitator wheel.

Other types of product than mentioned above can require a new canister type or conversion kit. The software has no extra configurations for those special canister/products. They can be used, but settings have to be changed manually in the Product settings in the Service menu. However, after doing that, the settings can be saved to USB flash disk to save for later use.

3.7.3 Taste card installation

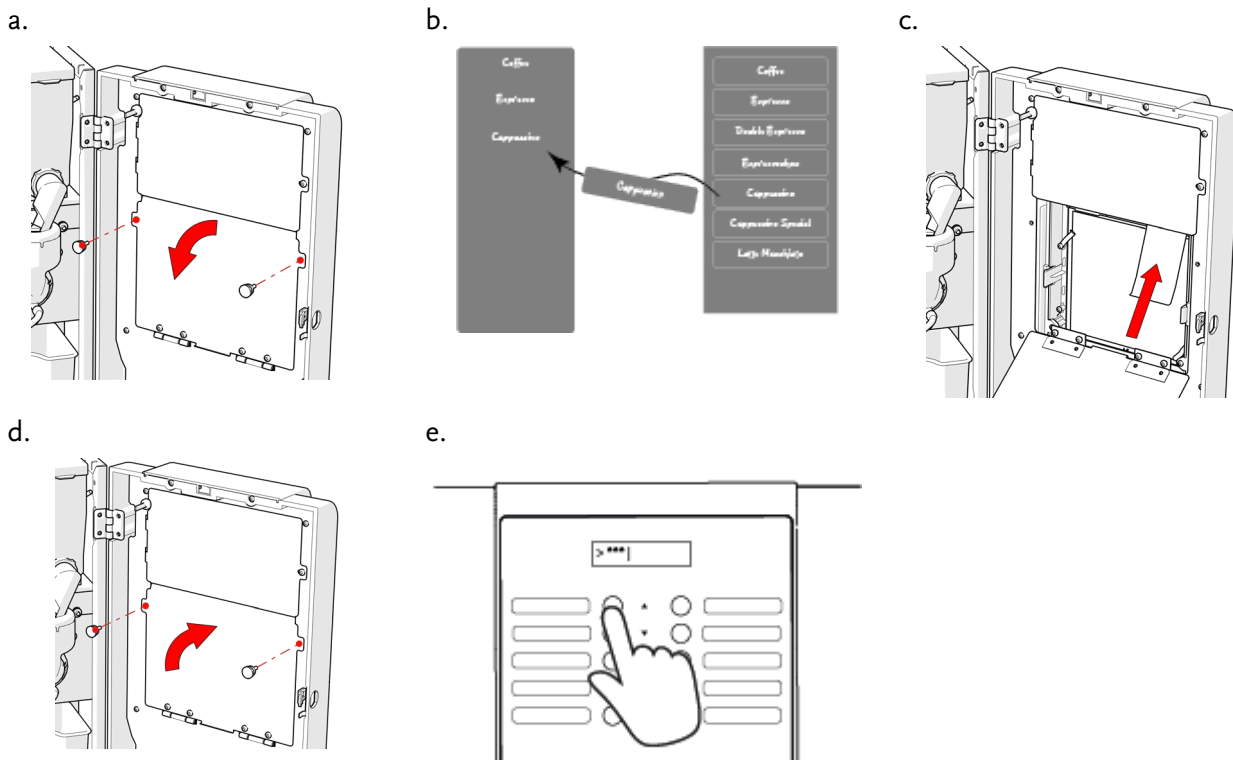

- 1 Open the lower panel of the door with the hand removable knurled nuts. (/3.4 a)
- 2 Place the product stickers on the taste card in correspondance with the standard or desired configuration. (/3.4 b)
- 3 Insert the taste cards in the slot of the plastic holder (/3.4 c).
- 4 Close the inner panel with the knurled nuts. (/3.4 d)

3.7.4 Using a customized key layout

- 1 Close and re-open the door to activate the Rinse menu.
- 2 Choose the password option and enter the password. (/3.4 e)
- 3 Change the configuration of the buttons.
- 4 Exit the menu.

3.8 Start Up

- 1 Open the front door of the machine.
- 2 Fill the bean canister with coffee beans.
- 3 Take the instant product canisters out of the machine with the outlet upwards.
- 4 Fill the canisters to maximum three quarters of the capacity. Don't press the contents. See paragraph 3.7.1 for the type and order of the canisters.



ATTENTION!

Maximum filling will lead to spillage and cause poor hygiene. Overfilling can prevent proper functioning of the machine. The products may not be tamped down!

- 5 Place the canisters back in the machine.

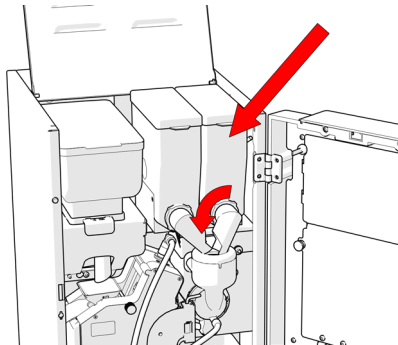

ATTENTION!

Mind that the outlets are turned downward inside the mixer.

- 6 Close the door.
- 7 Turn the machine on by means of the switch on the back of the machine.
- 8 The airbreak is empty, so will trigger the boiler filling procedure. Follow the instructions on the display or the following:
- 9 Place a container (>1 L) underneath both the main outlet and the hot water outlet and press start.
- 10 The airbreak and the boiler will fill with water. After that a message 'Temperature too low' will appear on the display.
- 11 Wait until the water in the boiler reaches the correct temperature. (The message 'Temperature too low' disappears from the screen.)
- 12 Open the door of the machine to activate the Rinse menu.
- 13 Rinse all lines of the machine through the Rinse option.
- 14 Close the machine door.

- 15 Press the “Go back” key to start operation. Adjust the machine for taste and quantity desired.
- 16 Choose every product at least twice to check the adjustment. See chapter 4 how to change flavours.

3.9 Customization of bean grind and product settings

This machine has been pre-adjusted for a general espresso grind and with general settings to provide the best in-cup quality. However, since the type of bean and instant mixture greatly affect the in-cup quality, the grind size, dosage and many other settings may need adjustments. See chapter 4 for a short introduction. Full support can be given by your dealer.

3.10 Instructions for the operator

After the machine has been installed and made ready for operation, the service technician has to instruct the operator, using this manual, regarding responsible maintenance of the machine according to the local guidelines. Safety and hygiene are central to this.

4 Adjustments



WARNING:

Only a qualified service technician may make adjustments to the machine!

4.1 Introduction

For appropriate measurement of all products and water quantities, several motors and valves are built in. Modern electronics allow different driving timing to be regulated precisely. Several combinations are possible that can be implemented, within certain limits, by the service technician. The machine will be delivered with a standard factory setting. You can always default back to this factory setting. Your dealer will see to it that your machine will be adjusted to your taste on your location.

Adjustment may only be performed by a qualified service technician.

The settings for quantities of product and water may differ per machine. Every machine has a unique machine number with a corresponding software version. If you would like to have the setting of your machine adjusted, this machine number is important for the dealer. The number is located on the identification plate which, depending on the model, is located inside the machine on the right hand side wall, top corner.

4.2 Products

This vending machine is solely intended for use with coffee beans and dry instant products. Use of a different product is not guaranteed to function well. Veromatic International BV is not liable for any damage or quality degradation if a different product is used. Consult your dealer which products can be used. Consult the regulations on the product packaging regarding the shelf life and replacement of the products used.

The machine is set to a specific volume with a predefined mixture and specific timings. This coffee machine is off factory provided with optimal settings which provide the best in-cup quality. Alternative products however may require some specific adjustment to guarantee the best result for your drink. Your dealer can help in making the right choice of products and its settings.

The quality of product depends on many factors, for example:

- The amount of coffee in the brewer.
- The amount and pressure of water running through the brewer.
- The grind size
- The duration of time that the product canister motor is on.
- The spiral auger used in the product canister to dispense the instant powder
- The amount of water added in the mixer.

4.3 Water temperature

The water temperature of the water inside the boiler can be adjusted by your dealer. In general the following applies:

- Temperature too low ⇒ Product does not dissolve adequately or wrong extraction
- Temperature too high ⇒ Water may start to boil under certain circumstances, causing a safety to turn off the machine. This has to be reset by a service technician before the machine can be put back into service

The operating water temperature may not be set below 65° C. Below this temperature bacteria will not be killed and the safety of the user can not be guaranteed.

4.4 Grinder adjustment

The grinder is off factory pre-adjusted for a regular espresso grind. If desired, this can be adjusted.

- 1 Open the door and enter the service menu (password protected).
- 2 Go to Product settings, choose 'Espresso' product, then 'Coffee' setting. This determines the grind time.
- 3 Remove the waste bucket and the espressobrewer.

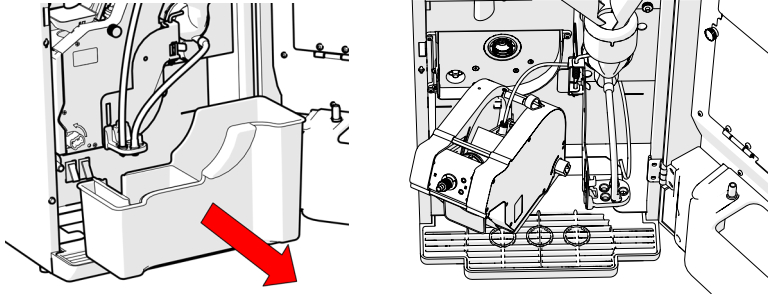

- 4 Place a small canister or large cup underneath the grinder outlet and press the 'jug' button to grind beans. Repeat this twice.
- 5 Throw the powder away and tare the scale.
- 6 Adjust the grind adjustment wheel counter clockwise for coarser grind, clockwise for finer grind.

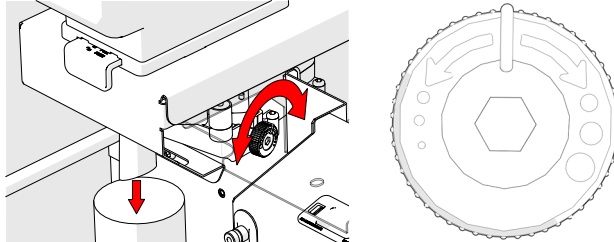

- 7 Repeat steps 5-9 until the required grind is reached.
- 8 The same process can be used to determine the grind time. Use a scale to measure the weight of the powder.
- 9 Make adjustments to the 'coffee' time setting, throw away the first three grinds, then weigh.
- 10 Re-install the brewer and the waste bucket.
- 11 The full (espresso) product can be tested from within this menu by pressing the 'hot water' key instead of the 'jug' key. Now a complete vend will be made.
- 12 Once satisfied, press back to exit the menu in steps. Each product can be adjusted by this process, although each with different settings, depending on the type.

4.5 Canister calibration

For the canister empty detection to work properly, the canister has to be calibrated to the installed beans and instant products.

- 1 Open the door and enter the service menu (password protected).
- 2 Go to 'Container settings', then threshold of coffee or instant canister. The 'jug' key will be lit.
- 3 Remove the espressobrewer and mixer.
- 4 Place a small container or large cup, hold it underneath the chosen outlet (grinder or instant).
- 5 Press the 'jug' key. Five powder dispenses will now be served.
- 6 Weigh the powder on a scale (tare the empty cup first).
- 7 Enter the value in the weight setting when asked in the display. Weight in grams.
- 8 The software then calculates the correct setting in the background.

5 Operation

The interface of the machine consist of:

- 1: Product keys 1 – 10 (8 product keys; 1 hot water key (right bottom); 1 jug key (left bottom))
- 2: Navigation Indicators (LEDs)
 - Up (operated with product key 1)
 - Down (operated with product key 2)
 - Go back (operated with product key 3)
 - Enter (operated with Start key)
- 3: Taste cards
- 4 Start key
- 5: Sugar strength (only the [-] and [+] are touch keys; the three white areas in the middle are only indicator lights)
- 6: Information display
- 7: Milk strength (only the [-] and [+] are touch keys; the three white areas in the middle are only indicator lights)
- 8: Coffee strength (only the [-] and [+] are touch keys; the three white areas in the middle are only indicator lights)

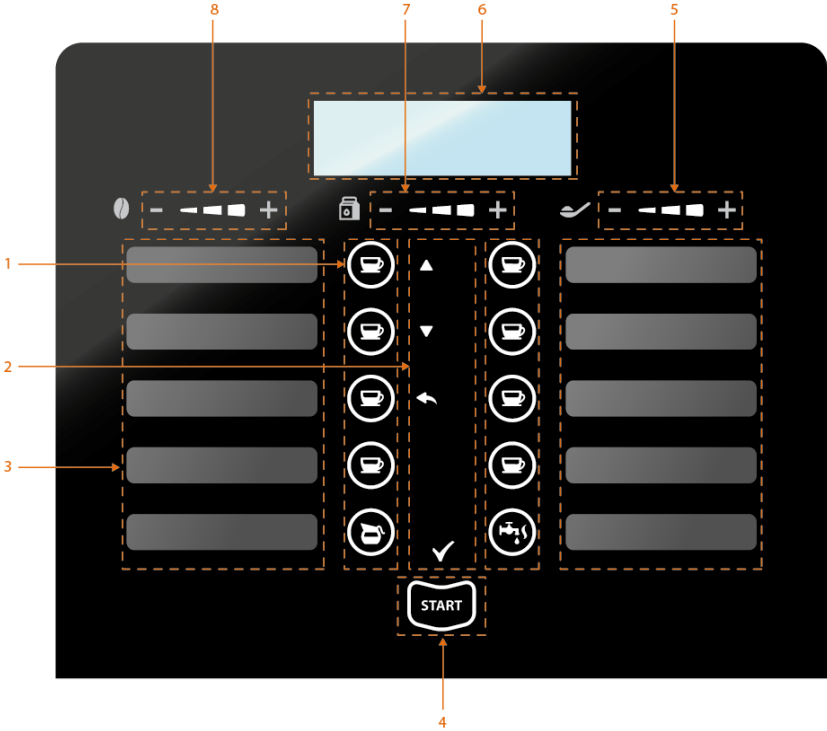

/5-1

A distinction is made between product/start keys (1&4) and navigation functions (2). When the product/start keys are active they will be lit. This is the case when a product should be selected or when a password should be entered. In settings, the navigation indicators are used solely as indicators and have to be operated by the product/start keys next to them, as the indication lights are not touch keys (/5-2).

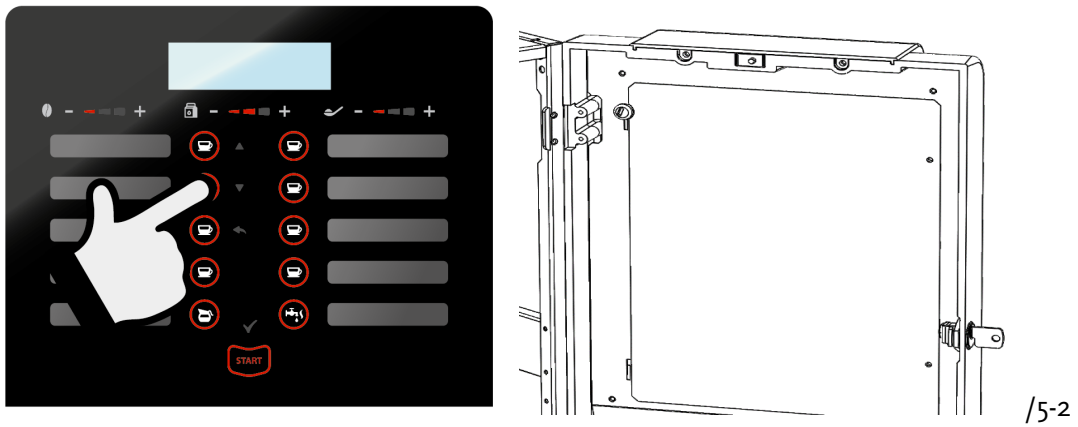

5.1 Taking a drink

- 1. Place a cup properly according to the cup positioning sticker. For hot water, place your cup on the right. For all other beverages, place the cup on the left side. The display will give direction. (/5-3)

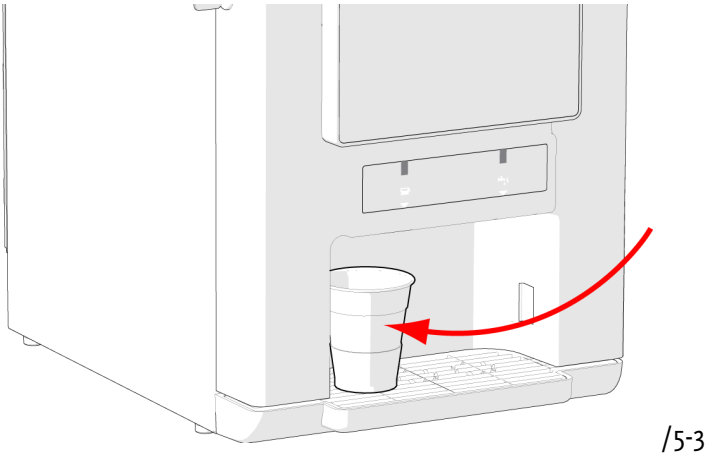

- 2. The interface will be in start position. All selectable keys will be lit (/5-4).



- 3. Choose the drink by pressing one of the active product keys. The other product keys will become inactive (/5-5). The START key will become active.

Note: When a pay system is attached, the display will show a message 'Insufficient credit', if the START key is pressed before having paid.

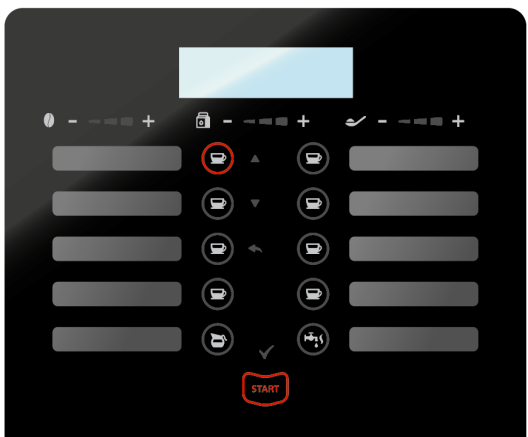

/5-5

- 4. If desired, adjust the strength of your beverage by using the strength adjusters [-] or [+]. The indicators will show the strength level.

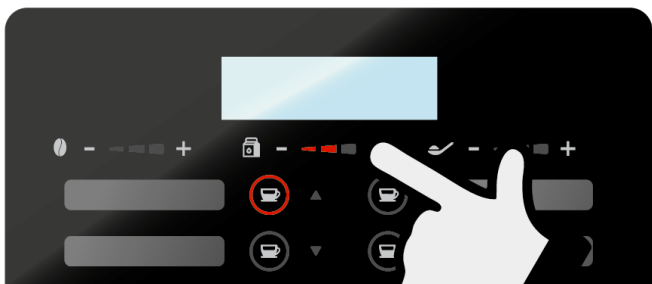

/5-6

- 5. If the cup sensor (when active) does not detect the cup, the machine will not dispense a drink. The display will show 'Place cup' (/5-7).

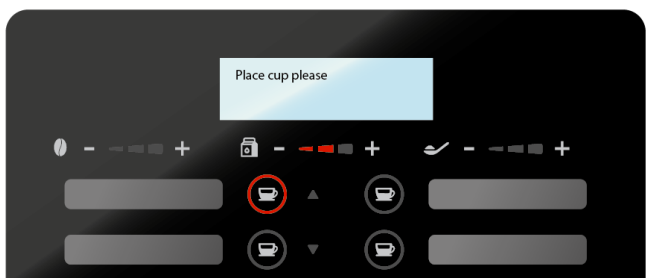

/5-7

- 6. If a glass is used and not detected, the system will ask you to confirm the dispense (/5-8)

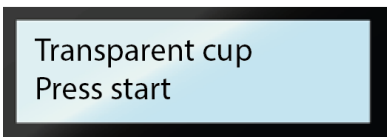

/5-8

- 7. Press the **Start** key to dispense the beverage. The chosen **product** key will blink during the dispense (/5-9).

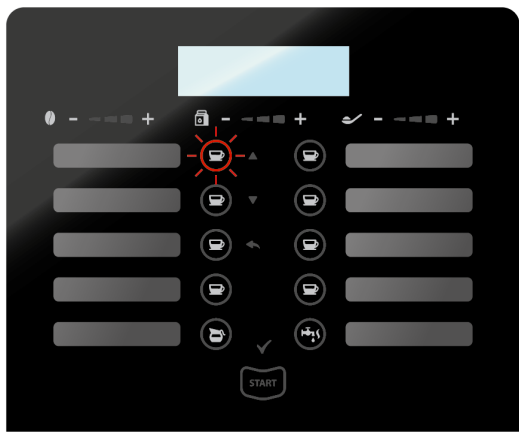

/5-9

- 8. After the beverage has been served, the display will show a message 'Your drink is ready'.

! WARNING:

Hot drinks may cause burn injuries. Keep your hands away from the cup or glass as long as the machine is dispensing your drink.

5.2 Hot water

Hot water is dispensed from a separate outlet so coffee will not pollute your water or tea. The hot water is the only function that can be stopped half way the process.

Press "Start" to start hot water dispensing. Wait until dispensing finishes, or press "Start" again to stop the dispensing halfway.

If hot water is chosen together with the milk strength, then it will make milk and dispense from the coffee outlet.

5.3 Jug/cup-to-go function

The jug key can be used to fill a small jug or a moderate cup-to-go (max. 12 cm high). This function can always be selected and deselected during the selection process. When the jug key is lit, the jug has been selected. The display will show the amount of consumptions that will be dispensed.

To stop the jug function half way, press "Start". It will finish the running dispense, and will not make additional dispenses.

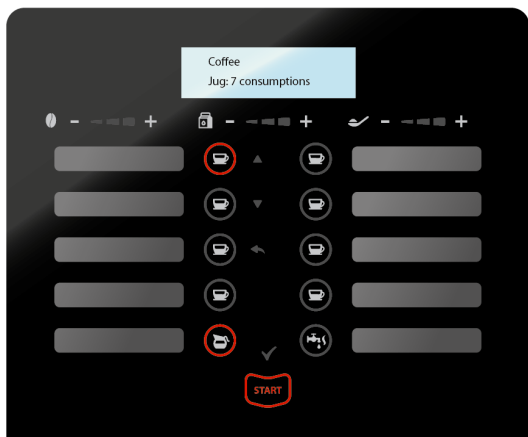

/5-10

5.4 Energy save mode (VIPS)

The machine is equipped with the Veromatic Intelligent Power Save (VIPS) energy saving turned on by default. In the first two weeks after installation (and after that continuously), VIPS will learn the usage of the machine. It automatically determines the timing for energy saving when no dispenses are made generally.

During the VIPS off mode, products can be dispensed only after pressing “Start”. This will activate the machine with the boiler heating again.

5.5 Rinse menu and service menu

By opening the door while the machine is on, the rinse menu can be entered. This menu is accessible for the operator and it contains functions for regular maintenance of the machine.



WARNING:

Maintenance may only occur by the operator or service mechanic. Even if the machine is not used much, this must be done daily.

6 Maintenance

Good maintenance is of the utmost importance. Hygiene and a good cup of coffee are very closely related. By strictly following the instructions the machine can be kept clean in a safe and efficient manner in accordance with the local regulations.



WARNING:

Never spray liquids into or against the machine.

Maintenance may only occur by the operator or service mechanic. Even if the machine is not used much, this must be done daily.

6.1 The maintenance area

Access to the maintenance area can be gained by inserting the door key in the door lock and turning it clockwise. Now the front door can be opened, after which the upper cover may be opened as well. The drip tray can be emptied without opening the door.

6.2 The service area



WARNING:

All areas where tools are needed to gain access are part of the service areas.

Access to the service area is restricted to persons having knowledge and practical experience of the appliance (a qualified and trained technician), in particular as far as safety and hygiene are concerned.

6.3 Freezing solid

The device may only be used indoors at temperatures between 10 and 32° C. If the device still is frozen accidentally, then take the following steps:

1. Turn off the machine
2. Unplug the machine from the wall outlet
3. Return the ambient temperature to room temperature
4. Call the service technician/dealer to have the device checked
5. Do NOT turn the machine back on. The internal components are filled with water and can become damaged if frozen, which causes the operation and the safety to no longer be guaranteed.

6.4 Machine overview

Outer parts:

- 1 Front door
- 2 Cabinet
- 3 Door key
- 4 Cup position sticker
- 5 Drip tray grill
- 6 Drip tray
- 7 Cup sensor
- 8 Branding light
- 9 Interface
- 10 Information display

Inner parts:

- 11 Upper cover
- 12 Bean canister cover
- 13 Bean canister
- 14 Grinder
- 15 Mixing bowl
- 16 Brewer
- 17 Product outlet
 - a) Espresso/instant products
 - b) Hot water
- 18 Waste bucket
- 19 Instant canister cover
- 20 Instant canister
- 21 Instant canister outlet
- 22 Door switch
- 23 Door inner panel
 - a) lower panel
 - b) upper panel

Back side parts:

- 24 Main power switch
- 25 Power plug
- 26 Water inlet

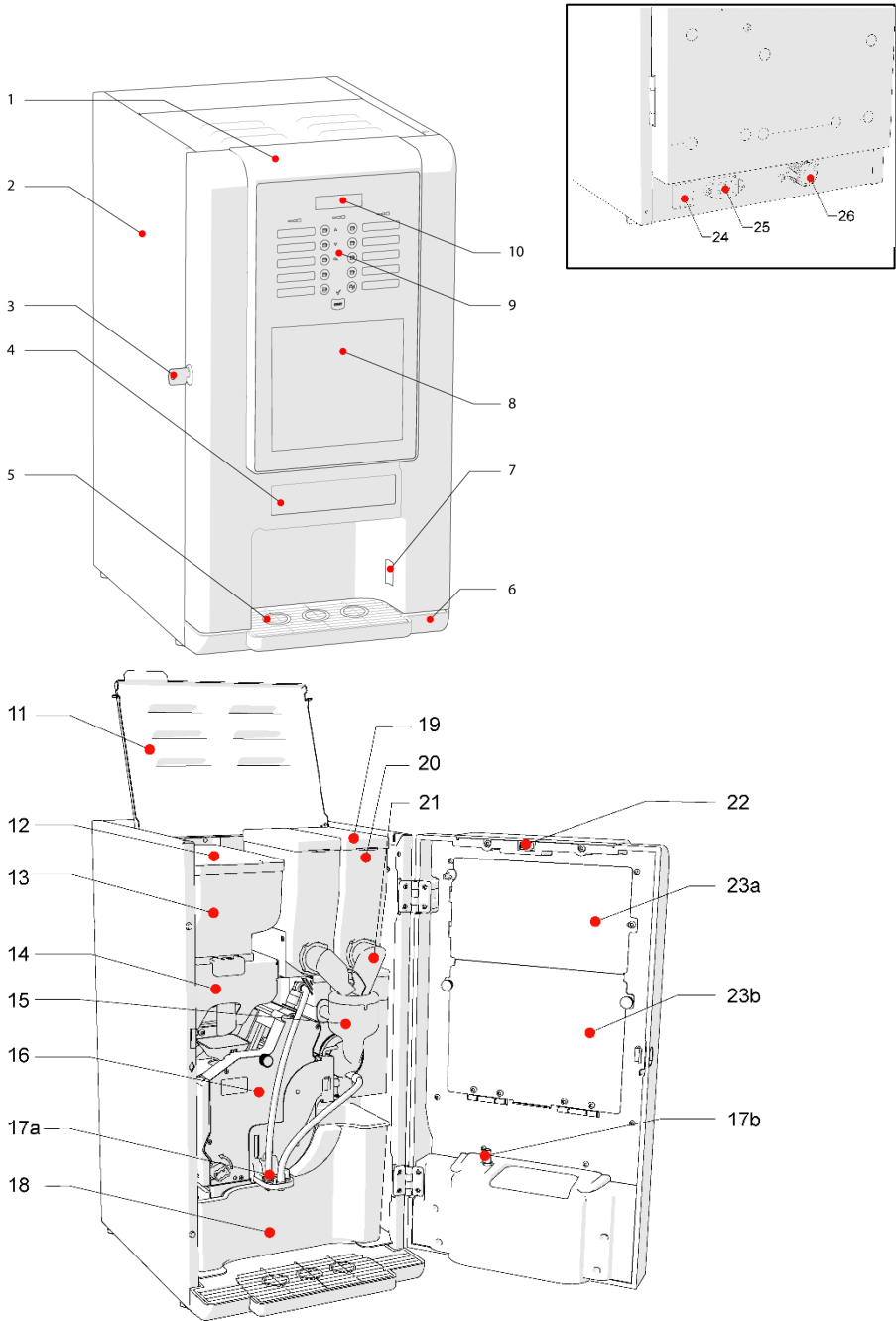

Needed accessories:

- brush
- dishwashing detergent

/ 6-1

6.5 Rinse/maintenance menu

For regular maintenance the dispenser is fitted with a Rinse/maintenance menu, with options to rinse the mixers, reset canister levels and read counters.

Many other options and settings of products and the machine are provided in the “Service menu”. These are only accessible for a dealer or mechanic with the appropriate password.

The Rinse menu is automatically activated by opening the door of the machine while it’s on. The navigation symbols will now be lit (/6-2). Press the product and start keys next to the lit symbols to navigate, confirm or go back (/6-3).

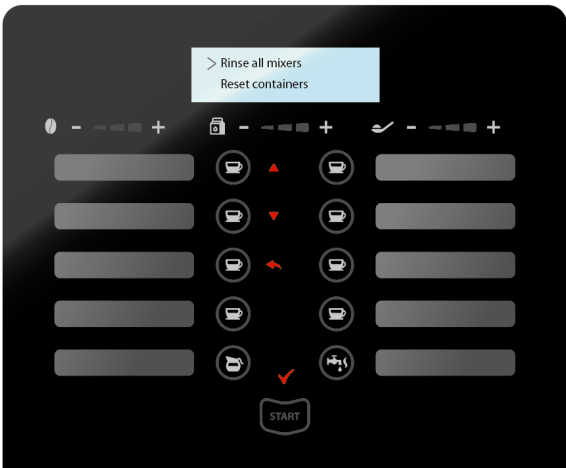

/5-2



/5-3

Scroll up

Scroll down

Go back

Enter

To leave the Rinse menu, the go back key should be pressed. The machine will go back to its start position. In the menu one can scroll through the options by using the scroll up and scroll down keys.

The following options are available in the Rinse menu:

- | Nr | Function |
|----|-------------------------------|
| 1 | Daily rinsing |
| 1a | Rinse all mixers |
| 1b | Rinse brewer |
| 1c | Rinse hot water |
| 2 | Brewer cleaning cycle |
| 3 | Reset container |
| 4 | Machine VIPS mode* / On / Off |
| 5 | Read counter |
| 6 | Grand total counter |
| 7 | Read log |
| 8 | Enter password?*** |

* VIPS = Veromatic Intelligent Power Save

** This is the gate to the deeper lying service menus. Intended for a dealer only.

6.6 Daily maintenance

For cleaning you may only use water, possibly with some dishwashing detergent. Always rinse thoroughly with clean water.

The machine is pre-installed with an automated daily rinsing option enabled each early morning. When active, it will ask to place a canister underneath the outlet and press start to start rinsing. When not active, it should be done manually. Full daily maintenance consists off:

- 1 Open the door of the machine to activate the Rinse menu.
- 2 Check the container spouts for stuck product. If so remove and clean them (dry).
- 3 Remove the waste bucket, empty it and place back in the machine.

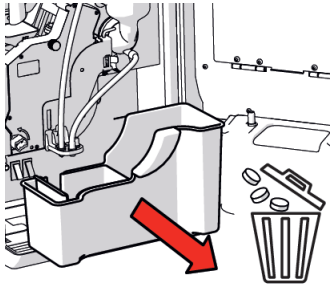

- 4 Place a canister or similar underneath the outlet.
- 5 Check for possible leakage during rinsing.
- 6 Rinse the brewer by selecting the function 'Daily rinsing' and then 'Rinse brewer'.

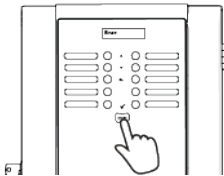

 **WARNING: hot water!**

- 7 Rinse the mixing systems by selecting the function 'Rinse all mixers'.
- 8 Repeat this rinsing once.
- 9 Turn the machine off with the mains switch.
- 10 Carefully remove the drip tray from the machine and remove the grill. Empty the drip tray and clean tray and grill with lukewarm water and a brush. The drip tray may not be placed in the dishwasher because that may damage the finish.

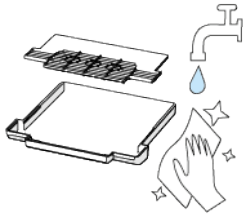

- 11 Remove the waste bucket and empty it.
- 12 Clean the dispense area.
- 13 Place the waste bucket back in place. Reinstall the grill in the drip tray and put the drip tray back in its place.
- 14 Close the door.
- 15 Clean the exterior of the machine with a light damp cloth.



- 16 Turn the machine on.
- 17 Press the “Go back” key to leave the Rinse menu and to resume normal operation (when the door was not closed).
- 18 Take a ‘test’ consumption of every product.

⚠ ATTENTION:

Be assured that following a maintenance all detachable parts are replaced to their normal position before restarting the operation of the machine.

The drip tray may not be placed in the dishwasher because it may damage the finishing of the surface.

6.7 Weekly maintenance

Perform all actions from daily rinsing (paragraph 6.6) and then extra:

6.7.1 Cleaning brewer

- 1 **Turn the machine off.**
- 2 Open the door of the machine.
- 3 Remove the waste bucket

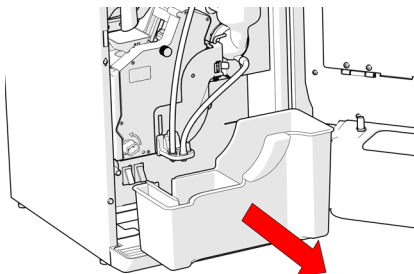

- 4 Flip the outlet to the side

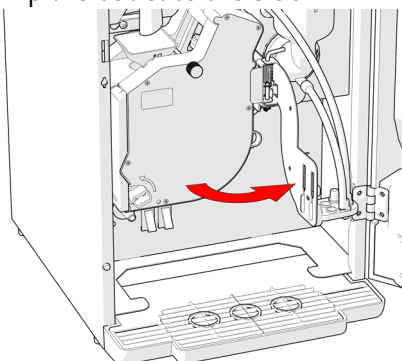

- 5 Remove the brewer hose from the outlet

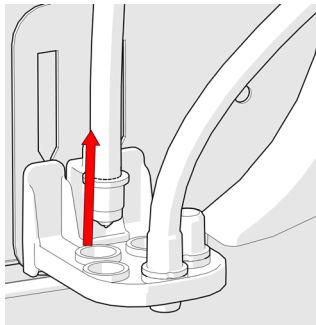

6 Remove the pin of the brewer and place it in the hole on the left of the cabinet.

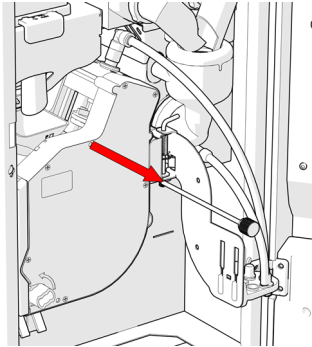

7 Carefully bend the click finger downwards and remove the brewer.

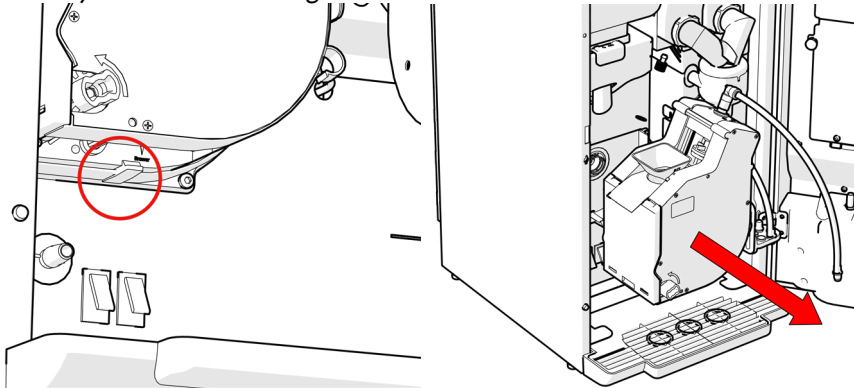

8 Place it on the side to easily access the inlet hose coupling.

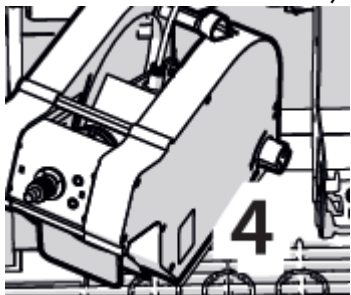

9 Disconnect the brewer hose by pressing the ring with one hand and pulling the hose with the other hand.

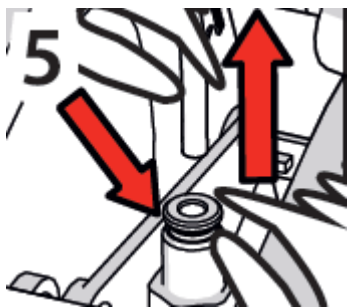

- 10 Rinse the brewer with warm water under the tap. Dry the brewer.
- 11 Reinstall the inlet hose thoroughly in the quick coupling at the bottom (see 25/26 in reverse)
- 12 Replace all parts in the reverse order. Check if the drive notch is aligned with the motor shaft and if the sensor carrier is aligned with the notch on the back of the brewer.

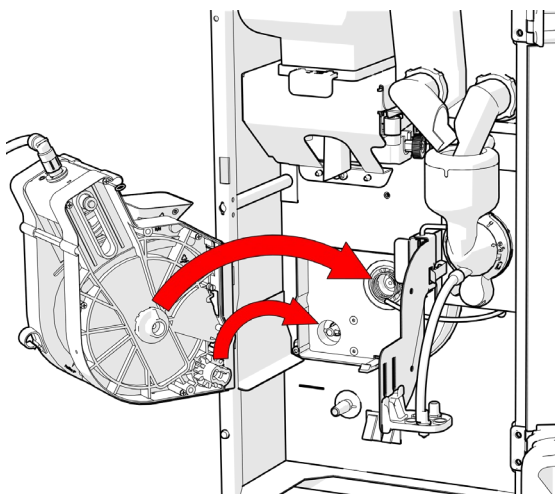

- 13 Fix the brewer with the pin.
- 14 Reinstall the waste bucket in the machine.
- 15 Close the outlet bracket.
- 16 Close the door.

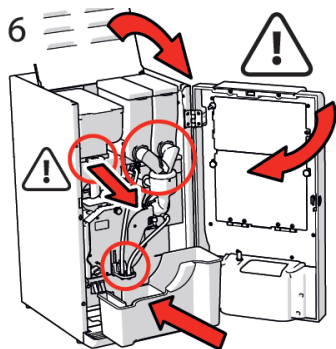

- 17 Turn the machine on.
- 18 Run a brewer cleaning cycle in the Rinse menu:
 - Go to 'Brewer cleaning cycle'.
 - Follow the instructions on the display.
 - Empty the drip tray and waste bucket when asked.
 - Close the door.
 - Place a large enough (± 1 L) container underneath the outlet to catch the cleaning liquid and confirm with Start.

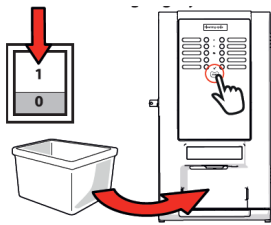

- The brewer is first pre-rinsed.
- Open the door and insert a cleaning pill in the brewer chute when asked. Regular pills of 1.6 gram are advised, max. is 3.5 grams.

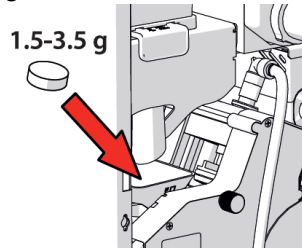

- Close the door, place the canister back underneath the outlet to catch the cleaning liquid and confirm with 'Start'.

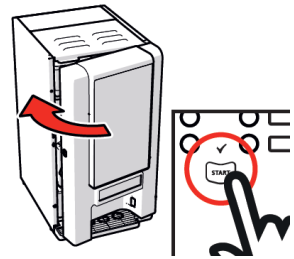

- Now the brewer is thoroughly cleaned. Attention: this proces runs for several minutes. It is important to let the machine finish the cleaning proces. Finally the brewer will be rinsed 3x and a espresso product will be given as a last step.

6.7.2 Cleaning instant mixer

- 1 Turn off the machine.
- 2 Open the door of the machine.
- 3 Turn the spouts of the instant product canisters upwards and remove the product canisters from the machine, starting with the left one (see 1-3).

Close the bean hopper by pressing the locking slide fully (a), tilt the hopper (b) and remove (c).

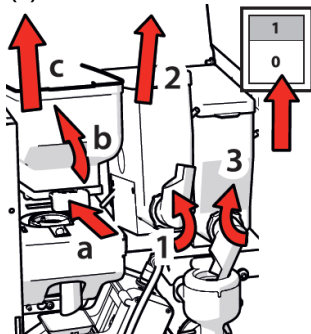

- 4 Clean the mixing system.
 - Remove the hose from the outlet.
 - Turn the mixer locking ring anti-clockwise to the unlock position.
 - Pull the mixer house and the funnel forward so they detach from the mixer plate.

- Remove the mixer paddle from the mixer axis.
- Remove the mixer plate by turning it further clockwise and pulling it from the base.
- Clean all parts in a bucket with hot water, brush them clean and dry.
- Clean the exhaust channel.

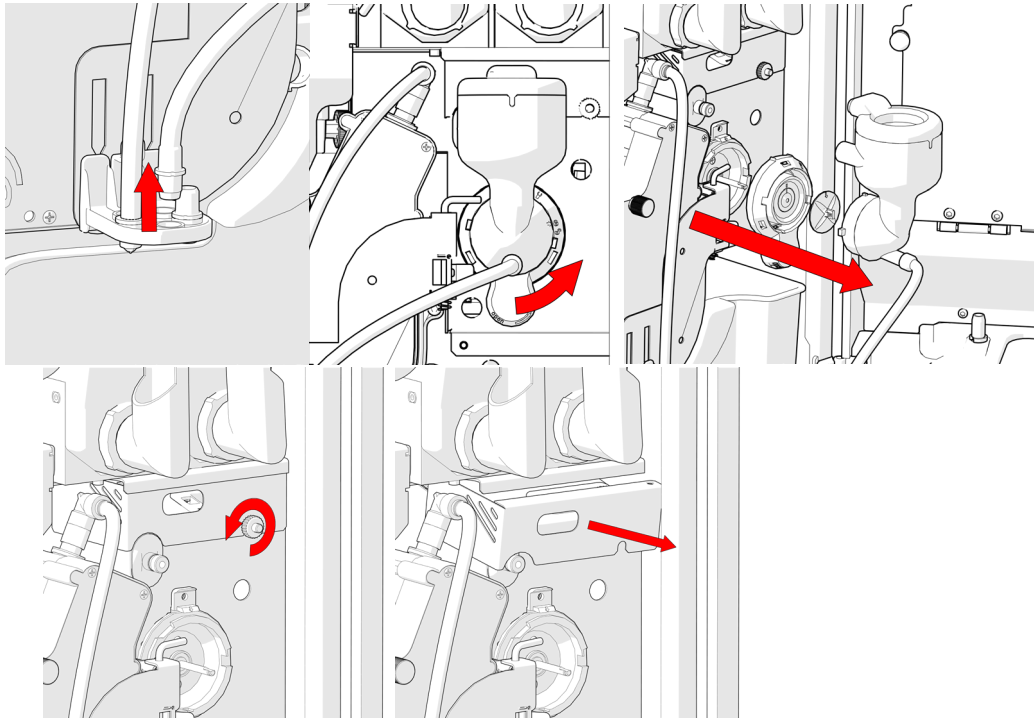

- Replace all parts in the reverse order. When placing the mixer house and the funnel on the mixer plate, remember to turn the mixer plate clockwise until you hear a click.
- 5 Clean the interior of the machine with a moist cloth.
 - 6 Place the product canisters back into the machine and make sure the spouts point in the correct direction.
To allow beans into the grinder, pull the locking slider towards you.



- 7 Reinstall the hoses.



- 8 Empty and clean the drip tray and the drip tray grate and replace them.

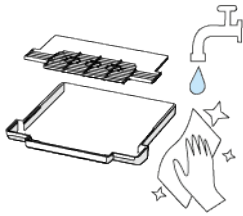

9 Close the top lid and the door.

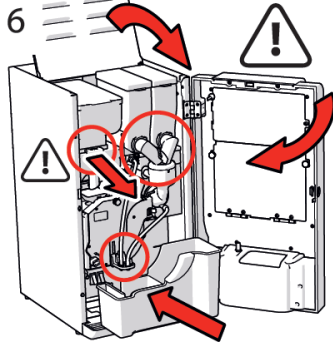

⚠ ATTENTION:

Be assured that following a maintenance all detachable parts are replaced to their normal position before restarting the operation of the machine.

10 Clean the outside of the machine with a clean moist cloth.



- 11 Turn the machine on.
- 12 Rinse the mixers → see paragraph o daily maintenance.
- 13 Close the door.
- 14 Press the “Go back” key to leave the Rinse menu and to resume normal operation.
- 15 Take a ‘test’ drink from each product.

6.7.3 Filling bean hopper

To ensure continued proper operation of this machine, it may only be filled with products that are prescribed by your dealer.

- 1 Open the door of the machine.
- 2 Open the upper lid.
- 3 Close the bean hopper by pressing the locking slide fully (a), tilt the hopper (b) and remove (c).

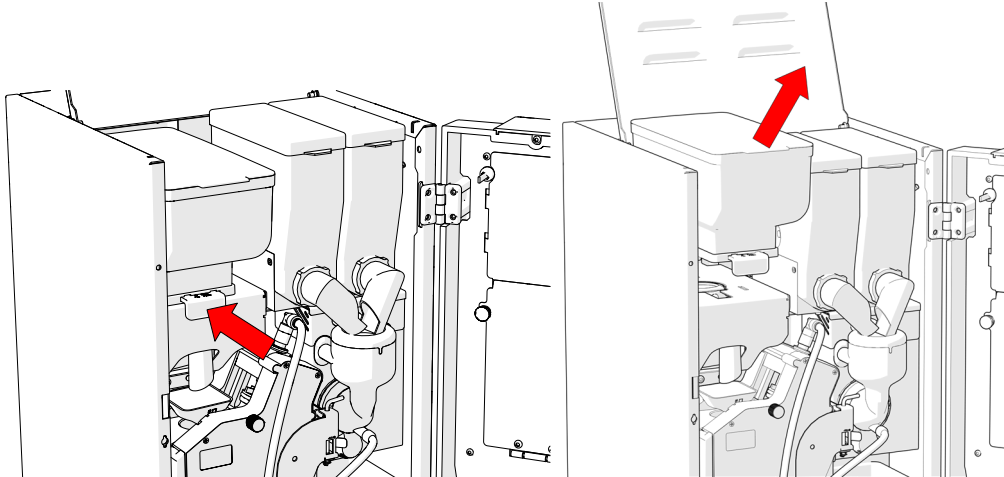

- 4 Fill the canister to maximum three quarters of the capacity and place back.
- 5 Place the hopper tilted backwards until the hook on the back slides in the slot, then tilt the hopper down.
- 6 To allow beans into the grinder, pull the locking slider towards you.



- 7 Close the door.
- 8 Reset the canister level in the menu.
- 9 Press 'Go back' to leave the menu.

Filling the bean hopper inside the machine

- 1 **The bean hopper may also be filled when installed in the machine, however to avoid spilling use above method.**
- 2 Remove the lid from the canister.
- 3 Fill the canister to maximum three quarters of the capacity and place back.
- 4 Close the door.
- 5 Reset the canister level in the menu.
- 6 Press 'Go back' to leave the menu.

6.7.4 Filling instant canisters

To ensure continued proper operation of this machine, it may only be filled with products that are prescribed by your dealer.

- 1 Open the door of the machine.
- 2 Open the upper lid.
- 3 Turn the spouts of the instant product canisters upwards and remove the product canisters from the machine, starting with the left one (see 1-3).

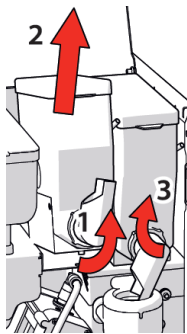

- 4 Place the canisters on the counter.
- 5 Remove the lids of the product canisters.
- 6 Fill the canisters to maximum three quarters of the capacity.

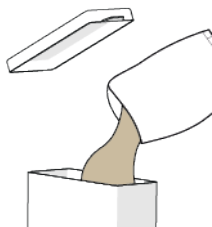

⚠ ATTENTION!

Maximum filling will lead to spillage and cause poor hygiene. Overfilling can prevent proper functioning of the machine. The products may not be tamped down!

- 7 Replace the lids on the product canisters.
- 8 Place the product canisters back into the machine.
- 9 Turn the spouts of the product canisters back into the correct position.

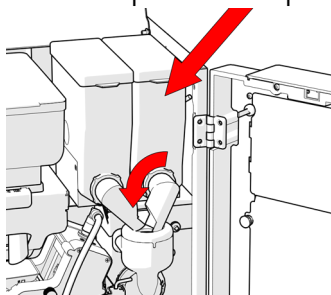

- 10 Rinse the mixer → see daily maintenance paragraph 6.6.
- 11 Reset the ingredient counters.

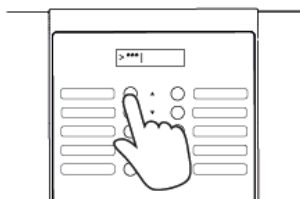

- 12 Close the upper lid and the door.
- 13 Exit the menu and take a 'test' drink from every product.

6.8 Monthly maintenance

In addition to the weekly maintenance, the following should be done:

- 14 Empty the canisters.



- 15 Check if there are no detached parts (like springs). If so, call your dealer/service number.
- 16 Clean the canisters with hot water.
- 17 Always place the canisters back in a **complete dry** state.

6.9 Annual maintenance

To continue the safe and hygienic operation of the machine it has to undergo a scheduled maintenance at least once a year. This may only be done by an authorized service technician. This person uses training information and service announcements supplied by the manufacturer.



ATTENTION!

By cleaning appropriately, one prevents formation of micro-organisms and accumulation of dirt in the machine; both cases cause taste and quality loss!

Thorough maintenance by you and the conclusion of a cleaning contract minimize problems.

8 Service menu

8.1 Extended machine settings

The machine menus are made up of three levels. The higher the level of the menu, the more settings can be changed. Access to a higher level is provided by a password code.

- Basic

Not guarded with a code ()
Least extensive menu for regular maintenance
Meant for an end user, instructed by the dealer to act as **operator** to fill and clean the machine (maintenance).

- Advanced

Guarded with a dealer code
Basic level expanded with dealer possibilities.

- Supervisor

Guarded by a mechanic code
Basic + Advanced level expanded with extra possibilities for mechanics.

For ease of understanding the levels are named.

- The basic level is called rinse menu / maintenance menu to make clear this is for easy maintenance such as cleaning, resetting canister levels and reading basic counters.
- The higher levels are all called service menu. This is for all upper levels, only the amount of settings differ per level. These extra settings are not for end users and operators, because they can mix up the machine operation in a bad way if not set properly.

8.2 Extended navigation

Scrolling through the menu is done with the navigation keys. With the ENTER key the menu will move to a deeper level and the BACK key returns to the previous level.

In the service menu two settings exist:

- 1) option menu, to choose from a predefined list
- 2) (alfa-)numerical edit field, to enter a value.

In an option menu, the navigation keys have the following functions (/8-1).

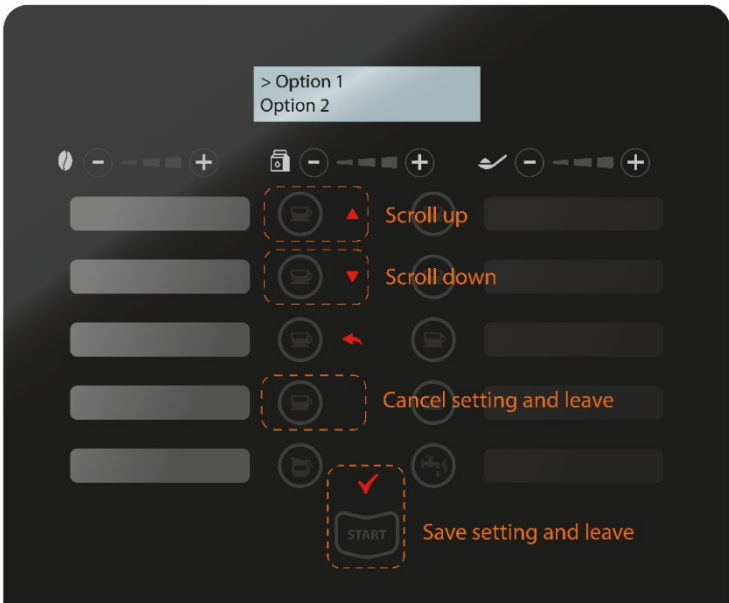

/8-1

By SCROLLING, the options can be selected.

By pressing ENTER, the desired option is saved and this menu is left to the previous branch.

By pressing BACK, the process is cancelled, the original setting remains, and the menu exits to the previous branch.

In an alfa-numerical edit field, the navigation keys work slightly different (/8-2).

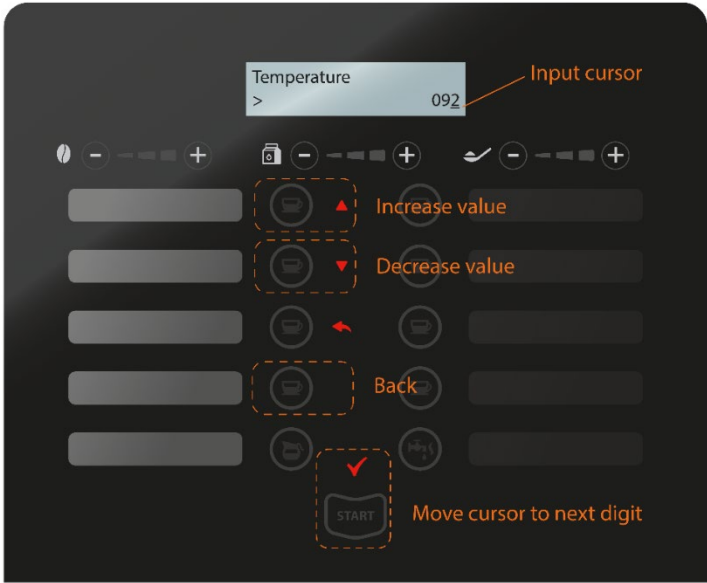

/8-2

With the SCROLL keys, the value (with the underscore cursor) can be changed with the UP/DOWN keys. To move to the next digit, the ENTER key can be pressed which moves the cursor one place.

The BACK key must be used to exit this edit field (as the ENTER has now a different function).

After leaving an edit field, the machine asks to save the new value. Acknowledge this by pressing ENTER. Press BACK to cancel the new value and restore the original value (/8-3).

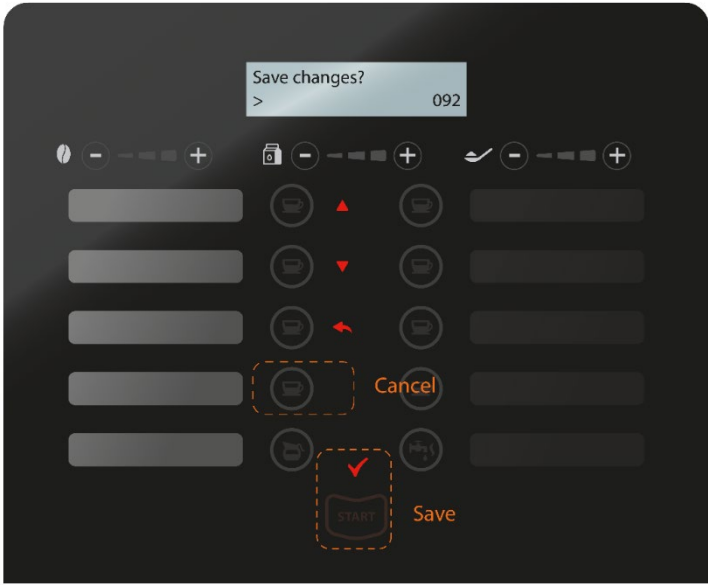

/8.3

For some deeper lying menus, a password has to be entered. In that case the navigation functions are deactivated. The indicator lights are not lit in this case. The first three round product buttons AND the ENTER/START key now determine the password code. See /8-4 for the values of the password keys. The password must NOT be acknowledged with START as this key is now part of the password digits.

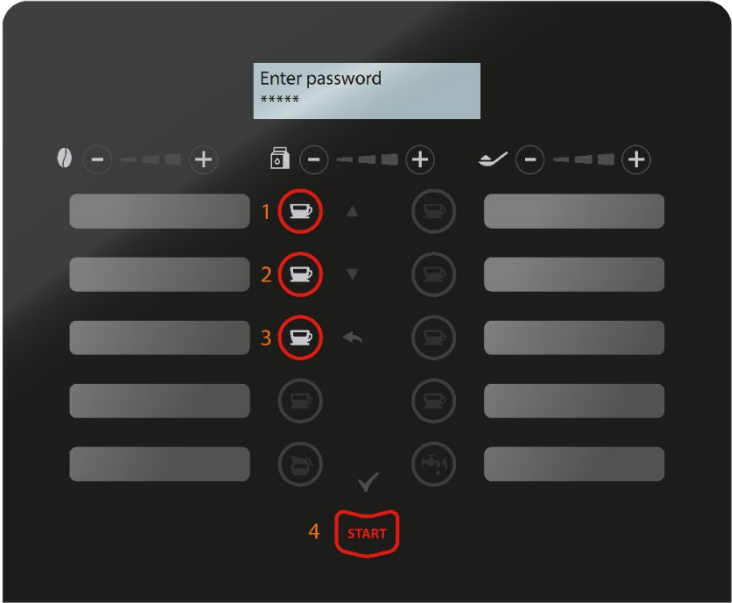

/8-4

When changing certain product settings, then first a choice must be made among the product keys, which will become lit (/8-5). By choosing a product key, the settings of that specific product appear. By pressing START, this menu will exit.

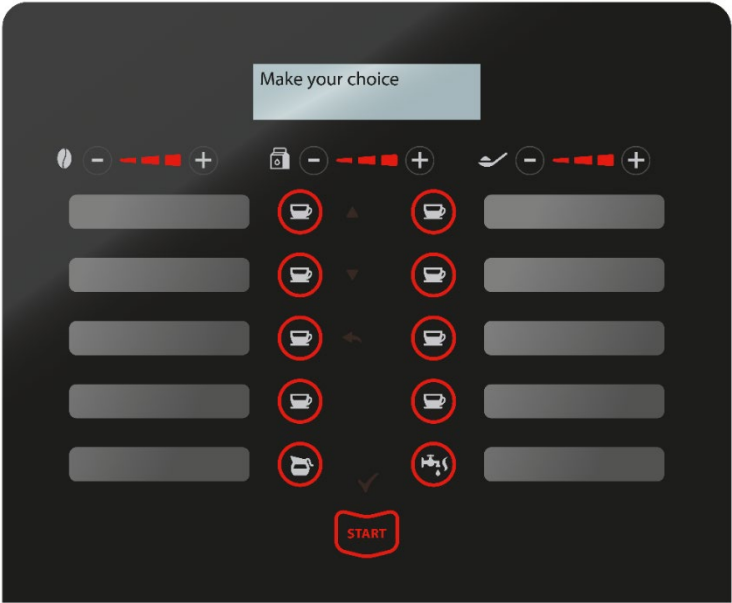

/8-5

8.3 BASIC - MENU LEVEL

For each menu, it is described here which functions are included. With advanced and supervisor, only those functions are described that have additional features.

Fucntion	Text in display	Details
1	Daily Rinsing	Rinse menu – daily
	Rinse all mixers	Daily rinsing of all mixers. The pulsation also helps to prevent build-up of lime at the valve.
	Rinse brewer	Daily rinsing of espresso brewer (without cleaning pill)
	Rinse hot water	Daily rinsing of hot water. The pulsation also helps to prevent build-up of lime at the valve.
2	Brewer cleaning	Weekly thorough cleaning program for espresso brewer, with cleaning pill.
3	Reset container counter	Reset container counters per type
3.1	Reset all	Press ‘Enter’ to reset all container counters at once.
3.1.1	Coffee beans	Reset coffee bean canister counter
3.1.2	Milk	Reset milk canister counter
3.1.3	Chocolate	Reset chocolate canister counter
4	Power management	Method of power saving management
4.1	Machine on	Machine manually set to always on
4.2	Machine off	Machine manually set to always off
4.3	VIPS mode	VIPS Veromatic Intelligent Power Saving Adaptive power saving according to real day use.
5	Read counter	Read product counters
5.1	Espresso	

5.2	Coffee	User can scroll the list by UP/Down Keys. Product name and count will be displayed on the screen. It is also possible to save counters to USB drive. Insert USB drive into the USB port on machine and press "Start" key. Follow the instructions on display to copy counters.
5.3	Café Americano	
5.4	Caffe latte	
5.5	Cappuccino	
5.6	Cappuccino Special	
5.7	Latte Macchiato	
5.8	Chocolate	
5.9	Hot Water	
6	Grand total counter	
7	Read log	Displays the list of logs that are recorded by the machine, which includes all the important events/error that occurs while machine is on. These are for diagnostic purpose.
8	Password?*	Enter Password to change the access level
		(The second line contains a 'pitcher' in case that the password is forgotten. The pitcher is a number between [brackets] and matches a predefined password in a recovery list.)

8.4 Password protection for higher levels

By entering the password, the extended menu levels are accessed. Passwords can be changed after installation; defaults are:

Default password advanced: 11111

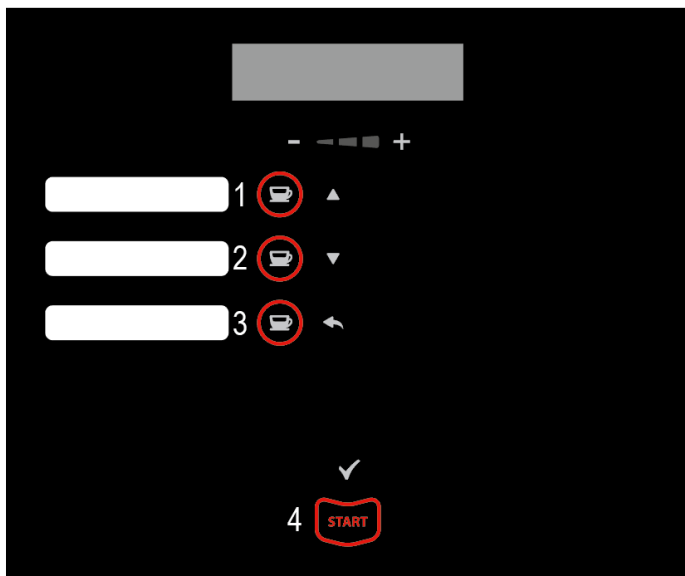

Default password supervisor: 22222

Button layout corresponding to password code digits:











If the password is forgotten or lost, below recovery list of the pitcher number can be used. The pitcher is a number between [brackets] shown on the second line of the (password) display.

Relation between pitcher and recovery password:

pitcher	 ADVANCED					 SUPERVISOR				
	1	4	2	1	2	2	1	4	2	1
2	3	4	4	3	3	1	2	4	1	1
3	1	1	1	3	4	1	4	4	4	3
4	2	1	2	2	4	3	1	1	4	4
5	3	1	3	3	3	3	2	3	4	3
6	1	4	4	1	4	4	3	4	4	1
7	4	3	2	1	1	1	4	1	1	4
8	3	1	3	4	4	2	4	2	3	4
9	4	3	1	4	2	2	2	2	3	4
10	3	1	3	4	3	3	1	4	1	4
11	4	2	3	2	2	1	4	1	2	1
12	4	2	2	2	3	1	3	4	4	1
13	3	4	2	4	2	3	1	1	2	3
14	3	2	1	4	3	2	4	2	2	3
15	3	1	3	2	4	4	2	2	4	3
16	3	2	4	4	4	1	3	3	4	2
17	1	2	2	4	4	3	3	1	3	1
18	1	4	2	4	3	2	2	2	3	2
19	3	4	4	1	3	2	2	2	1	4
20	1	3	1	4	4	4	2	1	3	3





















8.4.1 **ADVANCED -  & SUPERVISOR -  MENU LEVEL**



























Function	Text in display	Details	Level
1	Product Settings	Settings related to the vend products	
1.1	Product Prices		
	Price – Espresso	Scroll through the possible product list to set the prices. (Note: actual list may be different depending on configuration file and model selected.)	
	Price – Coffee		
	Price – Café Americano		
	:		
	:		
	Price – Milk		
	Price – Sugar		

1.2	Product Settings	(Note: actual list may be different depending on Product selected, configuration file and model selected).	
	Delay time coffee	Delay time before starting dispensing coffee powder (grinder)	
	Coffee	Time to dispense coffee powder/grind time	
	Extra coffee (milk/sugar)	Extra coffee powder / grind time when using by products	
	Pre-brew coffee water	Coffee/espresso water (time in seconds) for pre-brewing	
	Delay time pump	Delay time for espresso water pump to start	
	Delay time coffee water	Delay time for coffee water valve to open	
	Coffee water	Coffee Water run time (number of pulses of flow meter)	
	Coffee water (milk/sugar)	Extra coffee water when using by products (pulses)	
	Lag time coffee water	Pause/lag time coffee water after coffee dispense	
	Delay time brewer	Delay timer for brewer running after coffee dispense	
	Delay time milk water	Delay time before starting milk water	
	Milk water	Milk water dispense time (seconds)	
	Milk water pulse count	Pulsation count for milk water. Determines the number of breaks to dispense the milk water.	
	Pause/lag time milk water	Pause time for milk water between pulses/breaks	
	Delay time milk	Delay time before starting dispensing of milk powder in the mixer.	
	Motor duty cycle	Ingredient powder motor torque and revolutions limiter for controlling the dispense speed.	
	Milk	Milk powder dispense time (seconds)	
	Delay time milk mixer	Delay time before the mixer motor starts running.	
	Mixer duty cycle	Mixing motor torque and revolutions limiter for full strength or less powerfull mixing.	
	Running time milk mixer	Time that the mixer motor is running.	
	Delay time cacao water	Delay time before starting cacao water	
	Cacao water	Cacao water dispense time (seconds)	
	Cacao water pulse count	Pulsation count for cacao water. Determines the number of breaks to dispense the milk water.	
	Delay time cacao	Delay time before starting dispensing of cacao powder in the mixer.	









	Motor duty cycle	Ingredient powder motor torque and revolutions limiter for controlling the dispense speed.	
	Cacao	Cacao powder dispense time (seconds)	
	Delay time cacao mixer	Delay time before the mixer motor starts running.	
	Mixer duty cycle	Mixing motor torque and revolutions limiter for full strength or less powerfull mixing.	
	Running time cacao mixer	Time that the mixer motor is running.	
	Break time multicup	Pause time between multiple cup vends	
	Multicup enabled	Multicup enabled or disabled per product	
	Product strength	Product strength to be increased /decreased by percentage	
	Milk strength	Product strength to be increased /decreased by percentage	
	Sugar Strength	Product strength to be increased /decreased by percentage	
	Use Counter	Whether the counter is used.	
	Milk choice enabled	To use Milk as by-product	
	Sugar choice enabled	To use Sugar as by-product	
	Direct Start	To use Product as a direct start, once the product key is pressed it will not ask for confirmation and dispensing starts immediately.	
	Max. multicup count	Max. number of cups allowed when jug is selected (default = 3 or 7 depending on machine type).	
1.3	Product Key Layout	User can change the layout of the Product. All possible keys will lit. Select key then machine will prompt for available list of choices. Scroll through the list and choose the product. Product will get assigned to key.	
1.4	Load Defaults	All possible keys will lit. Select a key which you want to overwrite with default values and Press Enter.	
2	System Settings		
2.1	Pay Systems Settings		
	Point Position	Decimal point position for display.	
	Discount Percentage	Set here discount percentage to charge in discount mode.	
	Show Credit	To show or hide the credit on screen. If Disabled credit will be shown as '*****'.	
	Currency code	Scroll through the following list: EUR= Euro USD= US Dollar GBP= Pound XEU = ECU code (now absolute) XTS = Testing code JPY = Yen	

		NLG = //Obsolete. GRD= Dragma INR = Indian Rupee DKK = Danish krone	
	Charge Jug in single sum	All jug amount in one go	
	Milk Price	Price of a milk	
	Sugar Price	Price of a Sugar	
	Show exact change message	Display message: exact change.	
	Show comma in money value	Show comma in credit display.	
	Single vend	To enable/disable single vend.	
	Max. credit coin mechanism	Max credit that can be deposited in coin mechanism.	
2.2	Boiler Settings		
	Min. operating temp	Minimum temperature below which machine will not allow to dispense.	
	Temperature	Operating Temperature maintained by the machine.	
	Max. Temperature variation	Hysteresis of operating temperature.	
	Stand by temp	Temperature will be maintained by machine in power save mode.	
2.3	Jug Settings		
	Multicup allowed	Multicup to be allowed or not	
	Interrupt multicup at temperature	If multicup is selected then should it be interrupted because of temperature error or not. This gives a pause for the temperature to reach the set temperature again.	
2.4	Maintenance Settings		
	Use water filter counter	To enable water filter counter.	
	Use water filter expire warning	The number of the water filter counter at which the machine warns about replacing the water filter.	
	User water filter expire error	The number at which the machine should stop dispensing, before replacing filter.	
	Service date warning	Warning about service date. A set date at which it is advised to have service done periodically.	
	Service date error	Error message will display on and after date entered. Default is Off	
	Use daily rinse	To enable/ disable daily rinse. Triggers a rinse warning and procedure on a set time. To be acknowledged by the start key.	

	Daily rinse time	To set the time at which daily rinse activity will be started.	
	Use auto idle rinse	To enable/disable idle time rinse option. Triggers a rinse warning and procedure after a set time period in which no dispense was made. To be acknowledged by the start key.	
	Auto idle rinse time	To set the time period (in minutes) after which the auto rinse functionality will be performed.	
	Cold drinks use water counter	To enable/disable cold drink counter	
	Use Espresso cleaning warning	To enable/disable espresso cleaning warning	
	Espresso cleaning warning counter	Counter for cleaning warning espresso brewer in amount of cups. Default: 500	
	Use Espresso cleaning interval	To enable/disable espresso cleaning interval warning.	
	Espresso cleaning interval	Espresso cleaning interval in hours. Default: 168	
2.5	Container Settings		
	Use container empty error	Enable/Disable container empty error	
	Threshold Coffee beans		
	Threshold Milk powder	The value here represents powder in canister when it is full. Canisters have to be calibrated for this function to work correctly. See paragraph 4.5.	
	Threshold Chocolate Powder		
2.6	Select Language	Sets the user language from 4 set language. This only acts for the Rinse menu, not the Service menu which is always in english. (Default) EN- English NL- Dutch EN - English DE- German FR- French (Selected language will appear as default).	
2.7	Remaining Settings		
	Use Cup Sensors	To enable/disable Cup sensor	
	Use beeper	To enable/disable beeper on key press	
	Use fan continuous	To enable/disable fan continuously ON.	
	Fan on time	If fan continuous is disabled then fan will be ON for specified time after a dispense.	
	Branding brightness	Sets the brightness of the branding light.	
	Telemetry: Enable live event report	Enable/Disable live event report generation.	

3	Monitor Sensors	This is diagnostic screen use Up/down keys to scroll through to monitor sensors.	
	Espresso: Min. operating temp	Boiler Temperature and state of the heater (on/off)	
	Door:	Open/Close	
	Driptray:	Drip tray: Empty/ Full	
	Cup Left:	Cup Sensor L: Cup / No Cup	
	Cup Right:	Cup Sensor R: Cup / No Cup	
	Esp. brewer	In Rest/ Moving / In outlet / Removed.	
	Waste Bin:	Present / Not present.	
	Fan:	Fan: On/Off	
	Esp.W.Max:	Espresso water level max: Achieved/ Not Achieved	
	Esp.W.Min:	Espresso water level min: Achieved/ Not Achieved	
4	Power Management		
	Machine On	To set machine in normal or operational mode.	
	Machine Off	To set machine in Power save / stand-by mode.	
	VIPS mode	If VIPS is selected then, it will observe the user pattern for two weeks. Then according to usage, the machine automatically switches between Power save/Standby and On.	
	Reset VIPS mode	This will reset VIPS pattern stored. Starts collecting data once again.	
5	Pay System	Select pay system mode for machine. Scroll through the list and press Enter to set payment mode.	
	Paid	If machine is in paid mode. Pay system will be enabled. Machine will ask for credit to dispense a drink.	
	Discount	User will be charged with a discounted rate. Discount percentage can be set in <i>System Settings->Pay System -> Discount percentage.</i>	
	Free Vend	User can take drink for free.	
6	Counters		
	Espresso	Scroll the list by UP/DOWN Keys. Product name and Count will be displayed on the screen.	
	Coffee	It is also possible to save counters to USB drive.	
	Cafe Americano	Insert USB drive into the USB port on machine and press "Start" key. Follow the instructions on display to copy counters.	
	Caffe latte		
	Cappuccino		
	Cappuccino special	(Note: actual list may be different depending on configuration file and model selected.)	

	Latte Macchiato		
	Chocolate		
	Hot water		
	Grand Total Counter		
	Milk		
	Sugar		
	Water Counter		
	Dealer total counter		
7.	Reset Counters		
	Reset All		
	Espresso		
	Coffee		
	Cafe Americano		
	Caffe latte		
	Cappuccino		
	Cappuccino special		
	Latte Macchiato		
	Chocolate		
	Hot water		
	Milk		
	Sugar		
8.	Clock		
	05/02/2017	Set the clock with UP/DOWN and Enter keys. Depending on access level user logged in can edit Date and/or time settings.	
	18:24:00	Date is in DD/MM/YYYY and time in HH: MM: SS 24Hrs format.	
9.	Log	Displays the list of logs that are recorded by the machine, which includes all the important events/error that occurs while machine is on. These are for diagnostic purpose. User can copy log file to USB	
10.	Factory Menu		
	Load factory defaults	This will erase all current settings and load factory defaults. Here the choice can be made to change the configuration type.	

	Merge settings from USB	To Merge the settings to the actual settings	
	Save Settings to USB.	To save settings from the current machine to USB	
	Test Programs	To view or to start the Factory test programs	
	Empty Boiler	To start the process of emptying the boiler.	
	Load Software	To load new "PP58.bin" file from the USB. Select folder and load new file	
	Load Bootloader	To load new bootloader	
11.	Password		
	Enter password	Enter Password to change the access level.	
	Change password	User can change the password he is logged in or the level below. To change the password user needs to select the level and enter new password. Available keys for password are Key 0, 2, 4 and Start key. After successful confirmation the password will change.	

9 Machine electronics

9.1 Overview electronics

Item	Code	Position	Description
Main control PCB	PP-00581	Back door	Control and IO of electronics, motors, boiler, sensors, etc.
Interface PCB	PP-00880	Front door	Control of human machine interface – display, buttons, LED's
Grinder converter PCB	PP-00851	Cabinet backside	Power converter and control unit for 230V DC grinder

Table 1 Control electronics in the MBE01 Espresso machine

9.1.1 PP-00581 main I/O board

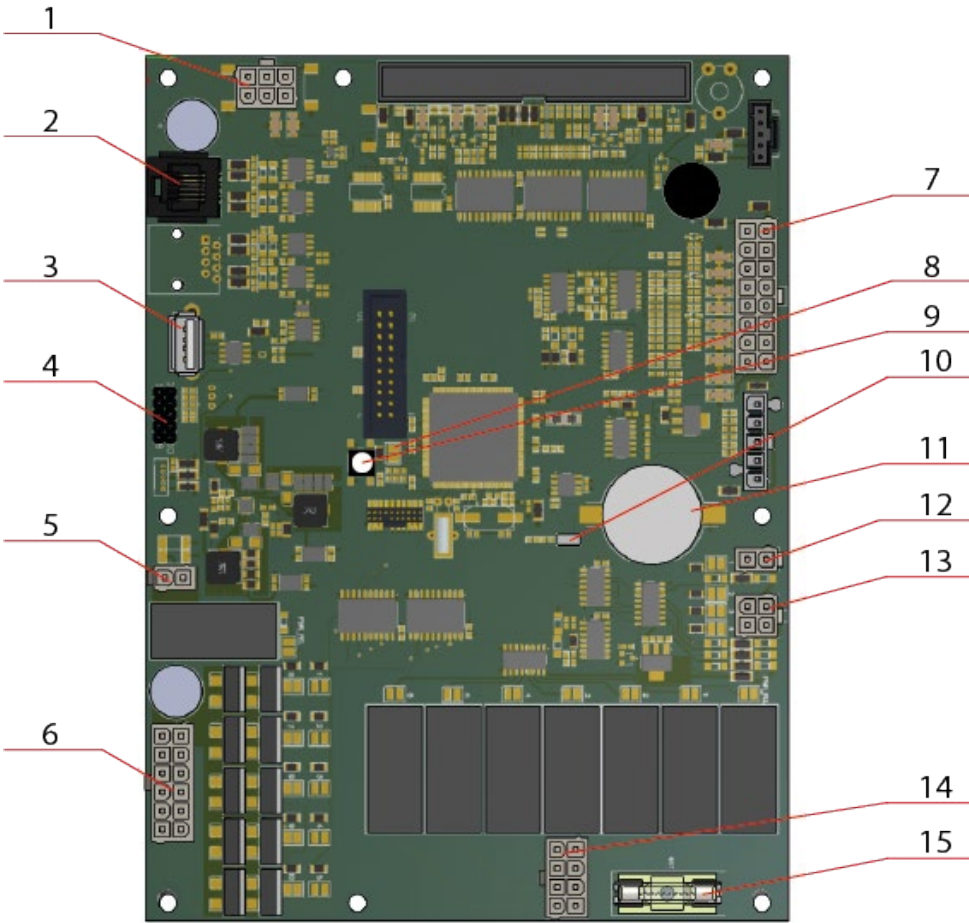

Part	Description
1	MDB (pay system)
2	Connection PP-00880
3	USB
4	Telemetry
5	Power
6	24V output
7	Sensors
8	LED
9	Boot button
10	Jumper
11	Battery
12	Fan
13	Heating element steering
14	230V output
15	Fuse (2A)

9.1.2 PP-00880 interface board

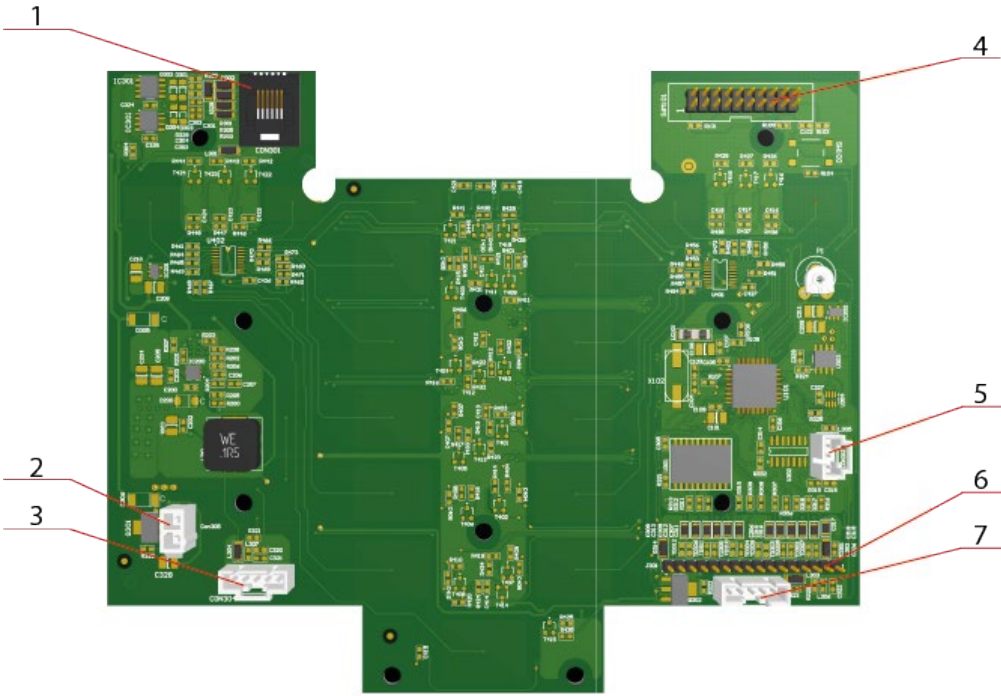

Part	Description
1	Connection to PP-00581
2	Branding LED panel 24V
3	Cup sensor (Right)
4	Program connector and boot button
5	Door switch
6	Display connector
7	Cupsensor (Left)

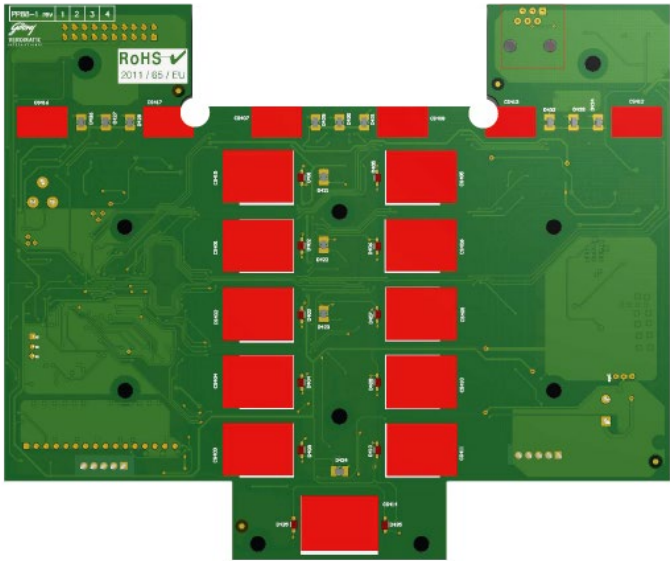

= capacitive touch
 & = LED

9.1.3 PP-00851 Converter and protection circuitry for 230 VDC grinding motor

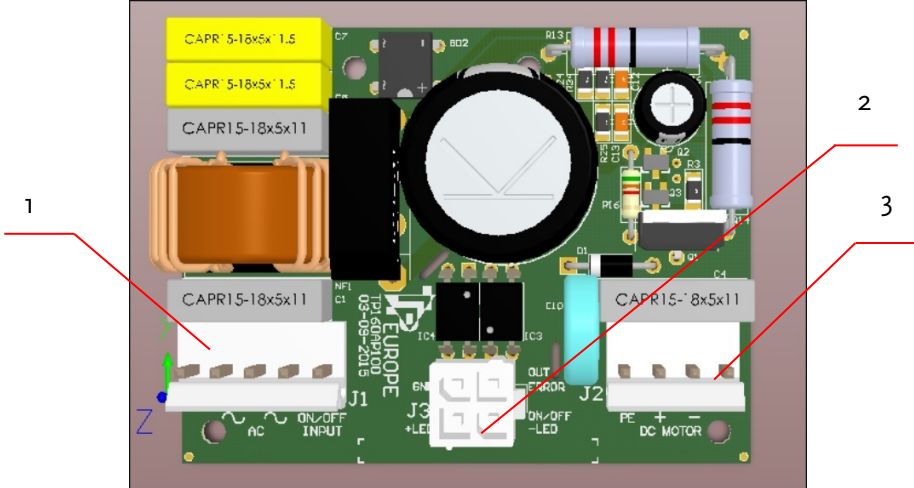

Part	Description
1	Input Connection from PP-00581
2	Encoder connection to PP-00581
3	Output Connection to Grinder Motor

The concerning circuitry is specially designed to protect the DC grinding motor(s) against overload situations.

Additional features are:

- when the motor is blocked the circuitry switches off the motor and send an error code
- when no beans are available the circuitry switches off the motor and sends an error code
- the grinding period is adapted according the AC input voltage to maintain the same amount of coffee at different AC voltages.

9.2 Electrical wiring diagram

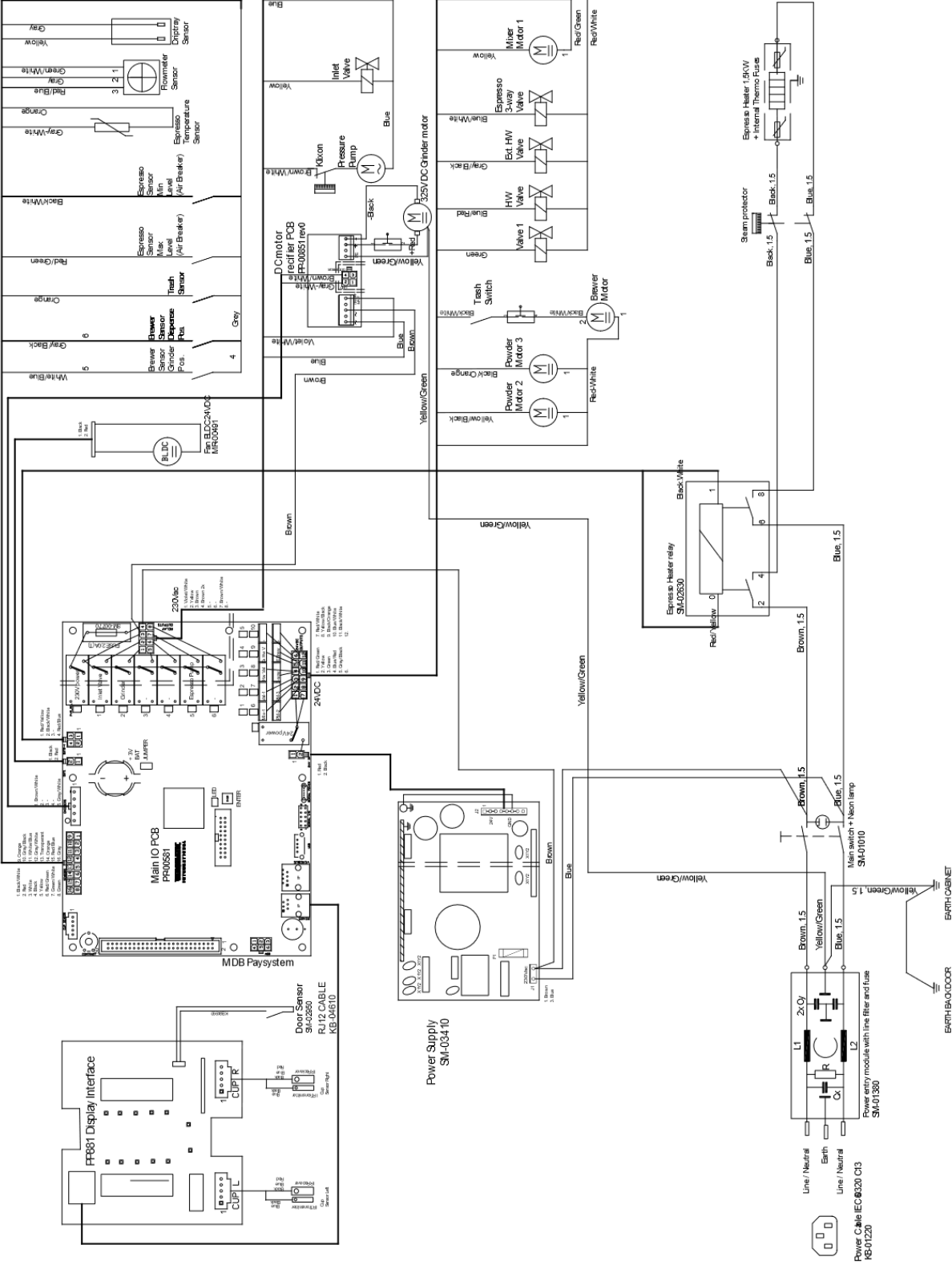

10 Service

10.1 Safety and hygiene

It is important for the safety and hygiene of the machine that it receives a service inspection each year and optionally parts are replaced. Use only original spare parts of Veromatic International BV.

Take precautions for your personal safety as described in the safety chapter in the beginning of this manual.

10.2 Water lock and water filter

Veromatic International BV strongly advises to use a water lock (ordering code HL-00190) to prevent high damages in case of leakages and will accept no responsibility nor liability with regard to water damage if the vending machine is installed without this protection.

A water filter is advised by Veromatic International BV to:

- keep the in-cup quality consistent
- minimise limescale buildup.

The filter must be replaced after a certain period (given by the supplier of the filter). A too long used water filter is detrimental to the operation of the machine and can be dangerous to health.

10.3 Safety inspection

- Check all seals for leakage, in special:
 - the boiler connections
 - the inlet valve
 - the outlet valves
- Check all electrical wiring. In special all wiring and connectors which are in connection with the heating element and replace if necessary.
- Check all hoses for cleanliness and tears and replace if necessary.
- Inspect all relais and replace if necessary.

10.4 Hygiene

For proper hygiene and safety, it is important to check the machine for proper maintenance; is there no accumulation of product residue in the outlets for example. If the machine is not well maintained, inform the operator of the risks and, if necessary, give proper instructions.

10.5 Maintenance schedule

Minibar Espresso		Yearly		Replace
		inspect	clean	each
AIR BREAK TANK	Empty and clean the air break tank. Check the hoses for damage or contamination. Check the working of the level sensors.	yearly yearly yearly	yearly - -	- if needed, max. two years -
FLOW METER	Check the hoses for damage or contamination. Check if the hoses are installed properly	yearly yearly	- -	if needed, max. two years -
BOILER	Empty the boiler and check for limescale. Descale the boiler when necessary, especially when no filter is used. Check the valve block and three way valve for signs of leakage. Check the seals of valve block, NTC sensor and replace if needed.	6 months 6 months 6 months yearly	yearly 6 months yearly yearly	- - - if needed, max. two years
PUMP	Check the pump for signs of leakage. Check if the hoses are undamaged, clean and installed properly - installed properly (not loose) - with clamps or tieraps for securing - undamaged (not running against sharp edges) and clean Check if the rubber mounting is not damaged and still soft. Check if the bypass is functioning	6 months 6 months yearly yearly	- - - -	- if needed, max. two years - -
GRINDER	Check the grinder and surrounding on residu and lost beans. Check the grind setting (coarseness and weight). Check the grind disc for (abnormal) wear. Check the motor for wear.	6 months 6 months 12 months yearly (20.000 cycles)	6 months - - -	- - 1000-1500 kg (approx. 80.000-120.000 cycles – dep. on several factors) max. 200.000 cycles
BREWER	Check if the brewer is maintained well. Clean thoroughly. Run an extra cleaning procedure and check: - the seals for wear. - the filter for wear. - the brew chamber for wear. Check if the couplings are fastened well. Check if the hoses don't have excessive dirt, discoloration or contamination.	every visit 6 months 6 months 6 months	3 months 6 months - if needed	- - yearly yearly if needed 2 years yearly
MIXER	Check if the mixer parts are cleaned properly by the operator. If contaminated too much, replace those parts. Check the locking ring: - the outer O-ring - the shaft seal (no signs of leakage behind on the shaft) Remove the motor: - check/clean the base ring from residu - clean the motor housing from dust/residu Check if the hoses don't have excessive dirt, discoloration or contamination.	each visit each visit yearly 6 months	3 months 3 months yearly -	if needed, max. two years yearly if needed yearly

CANISTERS	Empty the instant canisters and clean thoroughly. Re-place them completely dry. Empty the bean hopper and clean thoroughly. Depending on the beans used, the surface may get sticky. Re-place completely dry.			
CABINET	Check if the fan is clean. Check all wiring harnesses for signs of damage. Check the power cable for signs of damage. Check the water connection Check if the machine is maintained/cleaned properly by the operator. If not, clean the machine properly and instruct the operator.	6 months yearly 6 months 3 months every visit	6 months - - 3 months 3 months	- - if needed - if needed

When inspection shows defect / worn parts, they need to be replaced.

12 Malfunctions & repairs

12.1 Display malfunction messages

This machine features advanced malfunction analysis. When something is wrong, a message will appear on the display. Often the operator will be able to solve these malfunctions.

ATTENTION! The solution to the malfunction is only intended as a tip. You have to consult the extended instructions in the relevant chapters of this manual to find the solution to this malfunction. If you cannot solve the problem, please consult with your dealer.

Message type	Message	Solution
Warning	Machine requires service!	Warning about the service date that is coming up
Warning	Water filter dirty warning	Warning about the water filter that needs a replacement
Warning	Brewer not in position	(Re-)place brewer, waste bucket and close the door.
Busy	Temperature too low	Wait for the boiler to reach the required temperature
Busy	Boiler is filling	Wait for the boiler to reach the minimum water level
Error	Drip tray full	Empty the drip tray
Error	Boiler stopped filling	Restore water supply and restart the machine
Error	... container is empty	Refill the container and reset the counter
Maintenance	Service date reached	Machine needs service from the operator
Maintenance	Water filter saturated	The water filter needs a replacement
Serious error	Boiler error	Please call the operator

Other malfunctions are listed below:

Malfunction	Possible cause	Solution/Check
Machine only delivers water	The canister is empty	Fill the canister
	A canister is blocked	Remove the blockage
	A mixing bowl is clogged	Clean the mixing bowl
No action/lightning	Main power switch is off	Turn main power switch on at the back of the machine
	No mains voltage	Is the power cable attached appropriately?
Product is aqueous	Bridging in the canister or powder too old	Turn the canister once to loosen up the product
	Canister is almost empty	Fill up the canister and reset the counter
Machine asks to place a cup	Cup is not positioned appropriately	Position the cup appropriately

	A transparent cup is used (these are not always detected!)	Use the glass function (see 5.1 point 6) or use an opaque cup
Products not able to select, error brewer not in position	The door is open. The waste bin is not placed. The brewer is removed.	Re-)place brewer, waste bucket and close the door.
Espresso/coffee is much too light and/or only a fraction of the volume.	1. Brewer is clogged. 2. Ground powder (setting) is too fine.	1. Rinse the brewer, or additionally clean thoroughly by removing/cleaning and cleaning cycle (see 6.6.1 Weekly maintenance). 2. Ask your dealer to set the grinder more coarse.

Extended troubleshooting

Fault	Cause
No lighting	Ingredient canisters are empty Wiring faulty Door PCB faulty
No reaction on key press	Is pay system activated? Does the LED react? Is the wiring O.K.? Is the motor / valve O.K.?
No or insufficient water	Brewer clogged. Clean the brewer. Grinding is too fine. Set to more coarse grind. Is the inlet hose of the brewer connected? Is the inlet hose coupling properly tightened and not leaking? Is the mixer clogged? Is the water supply functioning? Hose kinked? Enough pressure on the tap? Water level correct in boiler? Switch the machine off, drain the air break tank and switch on. Perform a filling procedure. Water system scaling?
Pay system does not work	Is pay system activated? Wiring O.K.?
Water temperature too low/high	Too rapid succession of consumptions (max. 4 per minute)? Element O.K.? Temperature protection (clixons) have switched off the element? Switch the machine off, drain the air break tank, reset the clixons of the boiler and switch on. Perform a filling procedure. If problems persists, replacement may be needed.

12.2 Repairs



WARNING

Repairs are understood to be anything for which tools are needed to work on the machine. Those repairs may only be done by authorized technicians (see also paragraph 3.1). For any repairs only original parts may be used.

The demands made from a technician are:

- 1 The technician has to be informed of all laws and regulations regarding electrical connections, electrical symbols, etc.
- 2 The technician is very familiar with the machine, by training with Veromatic International B.V. or similar training obtained elsewhere.
- 3 The technician uses the instructions, diagrams etc., applicable for this type and model.
- 4 The technician takes all security precautions for himself and others so as not to be exposed to any danger, electrical as well as mechanical.
- 5 The technician is well aware of the applicable guidelines regarding hygiene.

The technician must take the following precautions while working on this machine:

- 1 Unplug the plug from the wall outlet.
- 2 Observe all general safety directions (see chapter 1)
- 3 Check to see if ground connections that have been removed are properly installed and functioning again. Failing to do so may cause a dangerous situation for both mechanic as users.
- 4 Micro-electronics are used in this machine. It is therefore necessary to wear a grounded bracelet with such service operations. For the same reason, the printed circuit boards that need to be repaired must be packaged in antistatic packaging material before they are transported.

To replace parts, use only original (spare) parts, issued by Veromatic International B.V. These satisfy strict quality demands which assure that the machine continues to function optimally. If original parts are not used, the warranty is null and void and Veromatic International B.V. is not responsible for possible damages resulting thereof.

13 Decommissioning

13.1 Temporary decommissioning

If the machine is not used for a longer period of time (starting at about 4 weeks) the following measures have to be taken by a service technician (for hygienic reasons):

- Turn off the machine off and let it cool down / warm up for 24 hours.
- Drain the boiler.
- Empty the product canisters (also turn over the crank filler (spiral) by hand).
- Carefully clean the machine (see chapter Maintenance).

If it turns out in retrospect that the machine has been out of commission for a longer period of time, the following has to be done by a service technician:

- Check all components for hygiene and damage.
- If needed replace dirty or damaged items.

Before commissioning again, see paragraph 3.8.

13.2 Disposal

If the machine is to be disposed of, the following has to be done by a service technician:

- Turn off the machine off and let it cool down up to 24 hours.
- Drain the boiler.
- Empty the product canisters (also turn over the worm drive by hand).
- Carefully clean the machine (see chapter Maintenance).
- Make sure the machine is complete.
- Hand in the machine.

If the machine is to be replaced by a new machine from Veromatic International B.V. the old machine will be taken back by the supplier for recycling.

For devices of Veromatic International BV a disposal fee has been paid. You can ask your supplier to pick up the machine and take it to specially allocated return stations. The return station will ensure that the machine will be recycled in such a way as to cause the smallest possible burden for the environment.

14 Technical information

Dimensions and weight

Height	594	mm
Width	310	mm
Depth	461	mm
Weight	32.0	kg

Capacity

Boiler	0.8	dm ³ (liters)
Product container beans	1.6	dm ³ (litres)
Product container instant	1.7	
Drip tray	0.75 (sensor level) 1.5 (max)	dm ³ (litres)

Environmental temperature

During operation	+10° to +32°	Celsius
During transport and storage	+0° to +50°	Celsius

Electrical details

Power supply	230	V~
Frequency	50	Hz
Electrical capacity	2000	W
Electrical safety class	Class I	
IP classification	IP20	
Pollution grade	2	
Overvoltage category	II	

Water connection

Water connection	3/4"	BSP
Water pressure	2.0 – 8.0	bar
	0.2 – 0.8	MPa
Water lock	Veromatic International BV instructs the use of a water lock (order code HL-00190) and does not accept any responsibility with regard to water damage, in case the machine gets installed without this water lock.	

14.1 EU-declaration of conformity

NL (original) EU-VERKLARING VAN OVEREENSTEMMING	EN EU-DECLARATION OF CONFORMITY	DE EU-KONFORMITÄTS- ERKLÄRUNG	FR EU-DECLARATION DE CONFORMITE
Veromatic International B.V. Donker Duyvisweg 56 NL-3316 BM Dordrecht Nederland			
wij verklaren geheel onder eigen verantwoordelijkheid dat het product:	we herewith declare, on our own responsibility, that the product:	wir erklären hiermit eigenverantwortlich dass das Produkt:	nous déclarons par la présente et sous notre propre responsabilité que le produit:
Drankenautomaat type: MBE01	Office machine type: MBE01	Automat Typ: MBE01	Machine type: MBE01
waarop de verklaring betrekking heeft, in overeenstemming is met de volgende normen:	which this declaration refers to, is in conformity, with the following norms:	Worauf sich diese Erklärung bezieht, die folgende(n) normes entspricht:	A laquelle cette déclaration se rapporte, est en conformité avec les normes suivantes:
EN 61000-3-2: 2014 EN 61000-3-3: 2013 EN 60335-1: 2012 EN 60335-2-75: 2004 EN 55014-1: 2017 EN 55014-2: 2015		migratie van lood en nikkel volgens NEN-EN 16889:2016 migration levels of lead and nickel according to NEN-EN 16889:2016 Migration von Blei und Nickel nach NEN-EN 16889:2016 niveaux de migration du plomb et du nickel selon NEN-EN 16889:2016	
<p>waarop de verklaring betrekking heeft, in overeenstemming is met de volgende richtlijnen:</p> <ul style="list-style-type: none"> - 2014/30/EU EMC Richtlijn - 2014/35/EU Laagspanningsrichtlijn - 2011/65/EU RoHS Richtlijn als gewijzigd door (EU)2015/863 - EG 1935/2004 Voedselveiligheid — veilige verpakking - EG 2023/2006 Materialen en voorwerpen die met levensmiddelen in contact komen — Goede fabricagemethoden - EG 10/2011 Materialen en voorwerpen van kunststof in contact met levensmiddelen 	<p>which this declaration refers to, is in conformity, with the following directives:</p> <ul style="list-style-type: none"> - 2014/30/EU EMC Directive - 2014/35/EU Low voltage directive - 2011/65/EU RoHS Directive as amended by (EU)2015/863 - EC 1935/2004 Food safety — safe packaging - EC 2023/2006 Materials and articles in contact with food — good manufacturing practice - EC 10/2011 Plastic materials and articles in contact with food 	<p>Worauf sich diese Erklärung bezieht, die folgende(n) Richtlinie entspricht:</p> <ul style="list-style-type: none"> - 2014/30/EU EMC Richtlinie - 2014/35/EU Niederspannungsrichtlinie - 2011/65/EU RoHS Richtlinie geändert durch (EU)2015/863 - EG 1935/2004 Lebensmittelsicherheit – sichere Verpackung - EG 2023/2006 Materialien und Gegenstände, die mit Lebensmitteln in Berührung kommen – gute Herstellungspraxis - EG 10/2011 Materialien und Gegenstände aus Kunststoff, die mit Lebensmitteln in Berührung kommen 	<p>A laquelle cette déclaration se rapporte, est en conformité avec les directives suivantes:</p> <ul style="list-style-type: none"> - Directive CEM 2014/30/UE - Directive basse tension 2014/35/UE - Directive LdSD 2011/65/UE modifié par (EU)2015/863 - EC 1935/2004 Sécurité des aliments: des emballages sûrs - EC 2023/2006 Matériaux et objets en contact avec les denrées alimentaires — bonnes pratiques de fabrication - EC 10/2011 Matériaux et objets en matière plastique en contact avec des denrées alimentaires
Dordrecht, the Netherlands,			
M. de Wildt Managing Director			
			
Date: September 1 st 2019			



• DUTCH DESIGN •
